



*Power of Smart Engineering*

# Product Design Layouts



**TECTRONICS**

*Power of Smart Engineering*

# **TG Home Series**

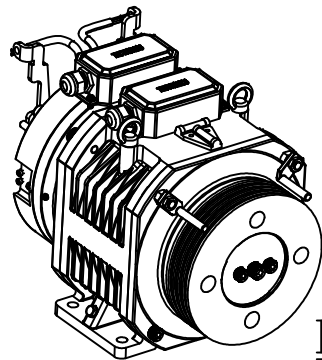
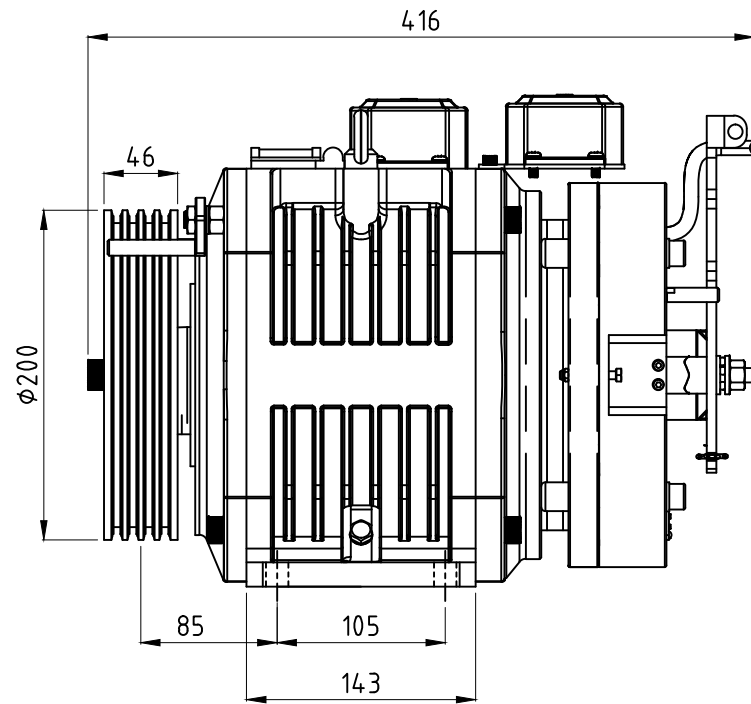
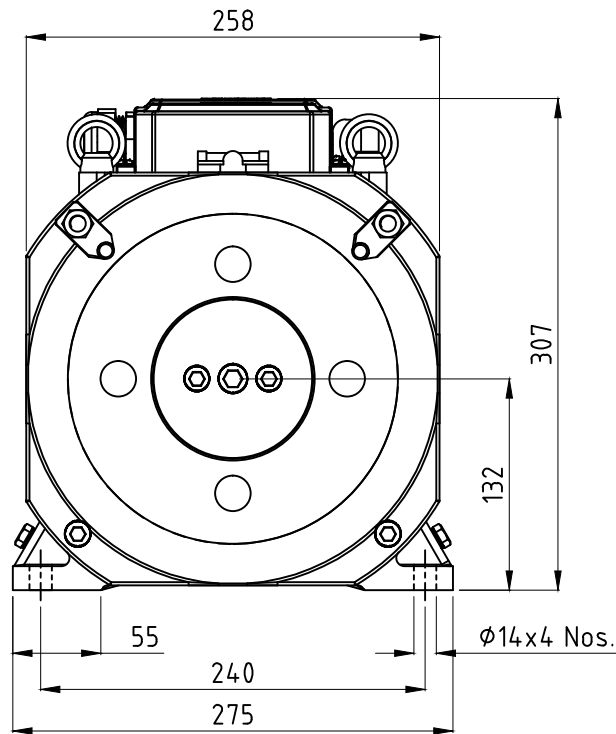

ISO VIEW

# MODEL-19 BRAKE IS ATTECH IN THIS MODEL.  
 # ALL DIMINTIONS ARE IN MM.

MATERIAL :		DIMENSIONS WITH TOLERANCE AND ★ (MARK) ARE CRITICAL.		WEIGHT : 160 KG
RAW PART NO. :		MODEL : TG 0404 - 200 (6 MM X 4 ROPE)		
		NAME	DATE	TITLE :
		DRN. NISHANT	28/10/18	
		CHKD.		
		APPD.		FINISH PART NO. :
		SCALE : NTS		
		~	FILING	SHEET 1 of 1
		▽	MACHINING	
		▽▽	FINE MACHINING	
		▽▽▽	GRINDING	
SR.	REVISION DESCRIPTION	DATE	NAME	

**LAYOUT**

**TECTRONICS ENGINEERS**  
**RAJKOT**

THIS DRAWING IS THE PROPERTY OF **TECTRONICS, RAJKOT**  
 IT SHOULD NOT BE COPIED OR ANY OF IT'S DETAILS DIVULGED  
 TO A THIRD PARTY WITHOUT OUR PRIOR PERMISSION IN WRITING  
 & MUST BE RETURNED TO US ON REQUEST.



*Power of Smart Engineering*

# **RTG 24P Series**



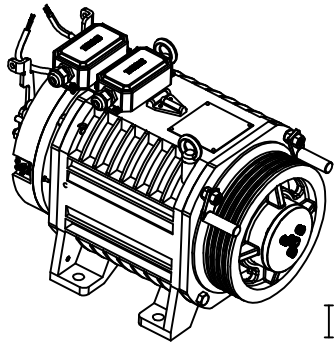
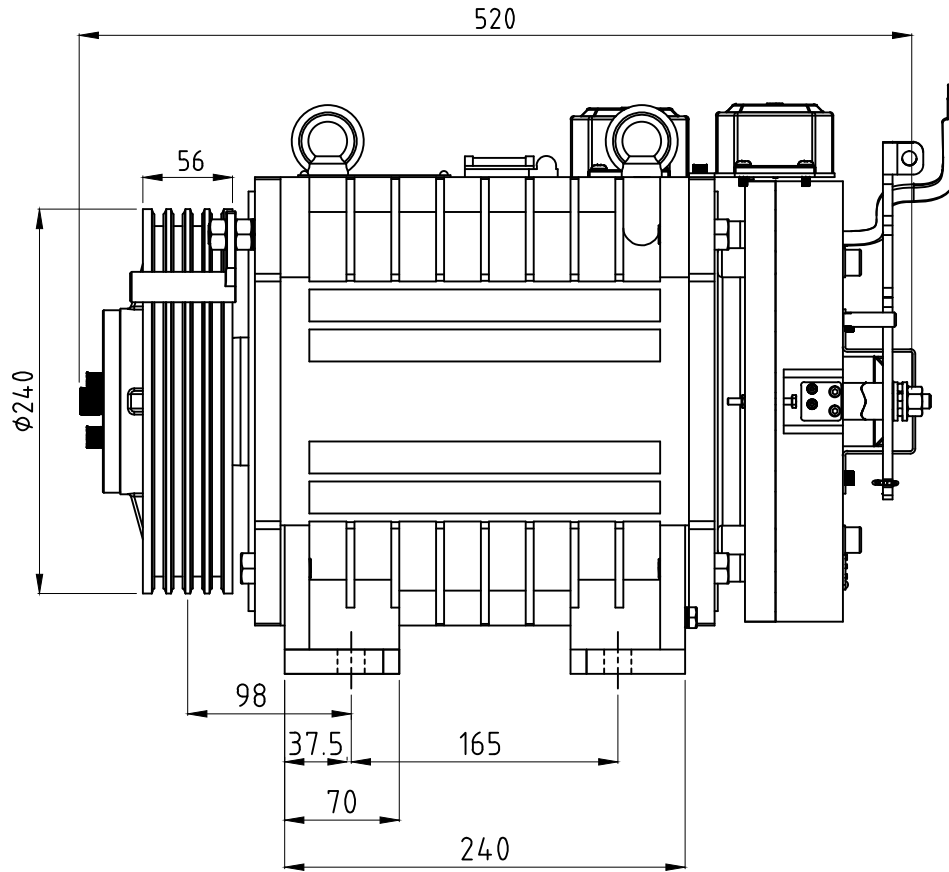
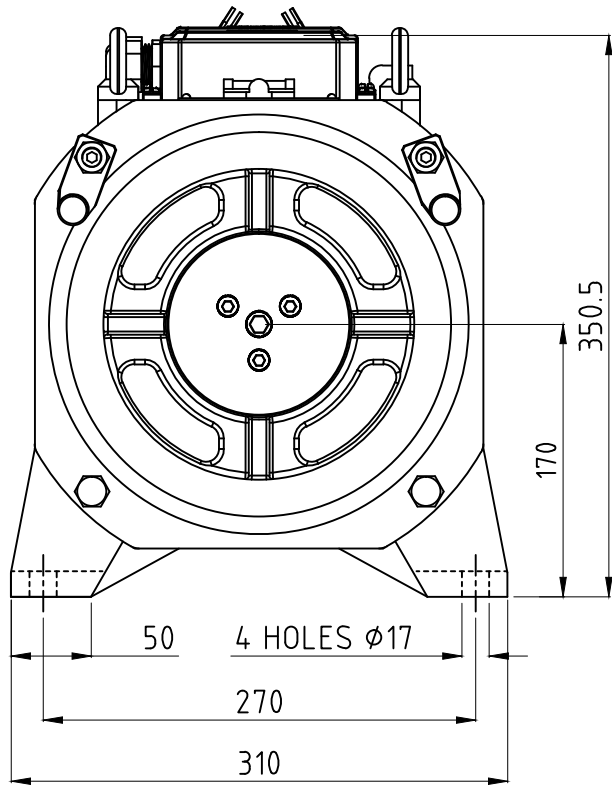

ISO VIEW

# MODEL-24 BRAKE IS ATTECH IN THIS MODEL.  
 # ALL DIMINTIONS ARE IN MM.

THIS DRAWING IS THE PROPERTY OF **TECTRONICS, RAJKOT**  
 IT SHOULD NOT BE COPIED OR ANY OF IT'S DETAILS DIVULGED  
 TO A THIRD PARTY WITHOUT OUR PRIOR PERMISSION IN WRITING  
 & MUST BE RETURNED TO US ON REQUEST.

MATERIAL :		DIMENSIONS WITH TOLERANCE AND ★ (MARK) ARE CRITICAL. WEIGHT : 160 KG	
RAW PART NO. :		MODEL : RTG 24P 0606 - 240 (8 MM X 4 ROPE)	
		NAME	DATE
		DRN. NISHANT	28/10/18
		CHKD.	
		APPD.	
		SCALE : NTS	
		~	FILING
		▽	MACHINING
		▽▽	FINE MACHINING
		▽▽▽	GRINDING
S.R.	REVISION DESCRIPTION	DATE	NAME
		TITLE : <b>LAYOUT</b>	
		FINISH PART NO. : SHEET 1 of 1	
		<b>TECTRONICS ENGINEERS RAJKOT</b>	

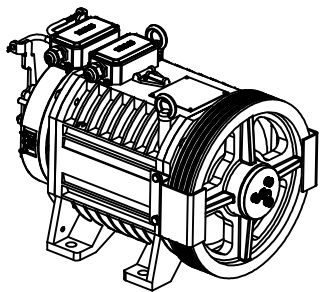
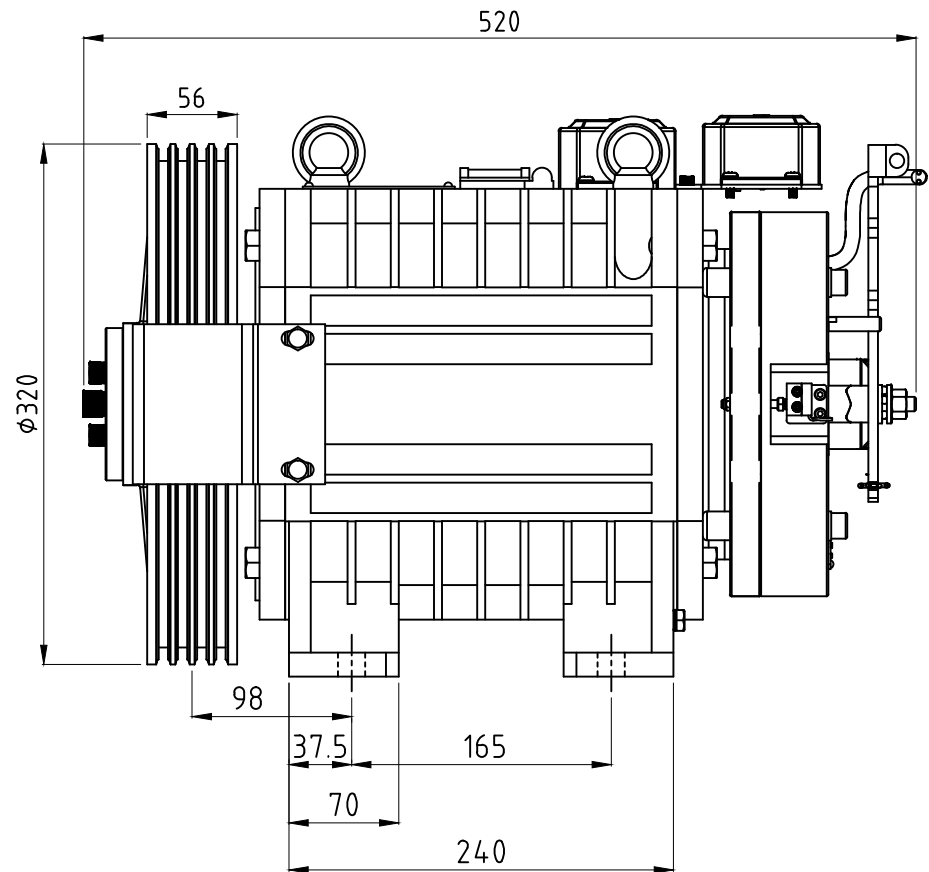
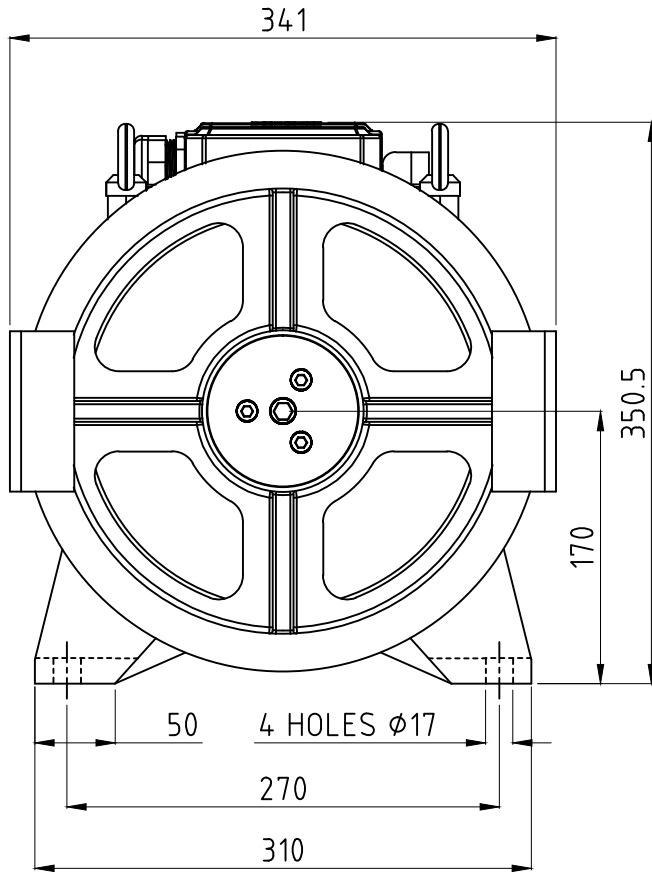

ISO VIEW

# MODEL-19 BRAKE IS ATTECH IN THIS MODEL.  
 # ALL DIMINTIONS ARE IN MM.

THIS DRAWING IS THE PROPERTY OF **TECTRONICS, RAJKOT**  
 IT SHOULD NOT BE COPIED OR ANY OF IT'S DETAILS DIVULGED  
 TO A THIRD PARTY WITHOUT OUR PRIOR PERMISSION IN WRITING  
 & MUST BE RETURNED TO US ON REQUEST.

MATERIAL :		DIMENSIONS WITH TOLERANCE AND ★ (MARK) ARE CRITICAL. WEIGHT : 160 KG	
RAW PART NO. :		MODEL : RTG 24P 0606 - 320 (8MM X 4 ROPE)	
	NAME	DATE	TITLE : <b>LAYOUT</b>
	DRN. NISHANT	28/10/18	
	CHKD.		
	APPD.		FINISH PART NO. : SHEET 1 of 1
	SCALE : NTS		
	~	FILING	<b>TECTRONICS ENGINEERS RAJKOT</b>
	▽	MACHINING	
	▽▽	FINE MACHINING	
	▽▽▽	GRINDING	
SR.	REVISION DESCRIPTION	DATE	NAME

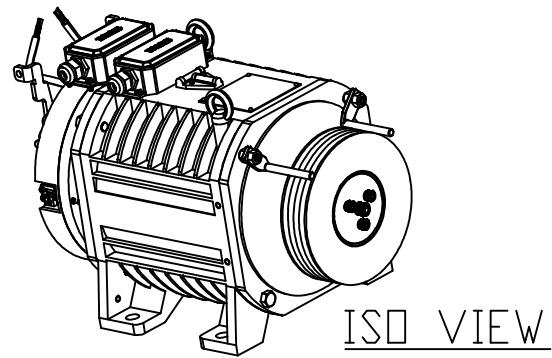
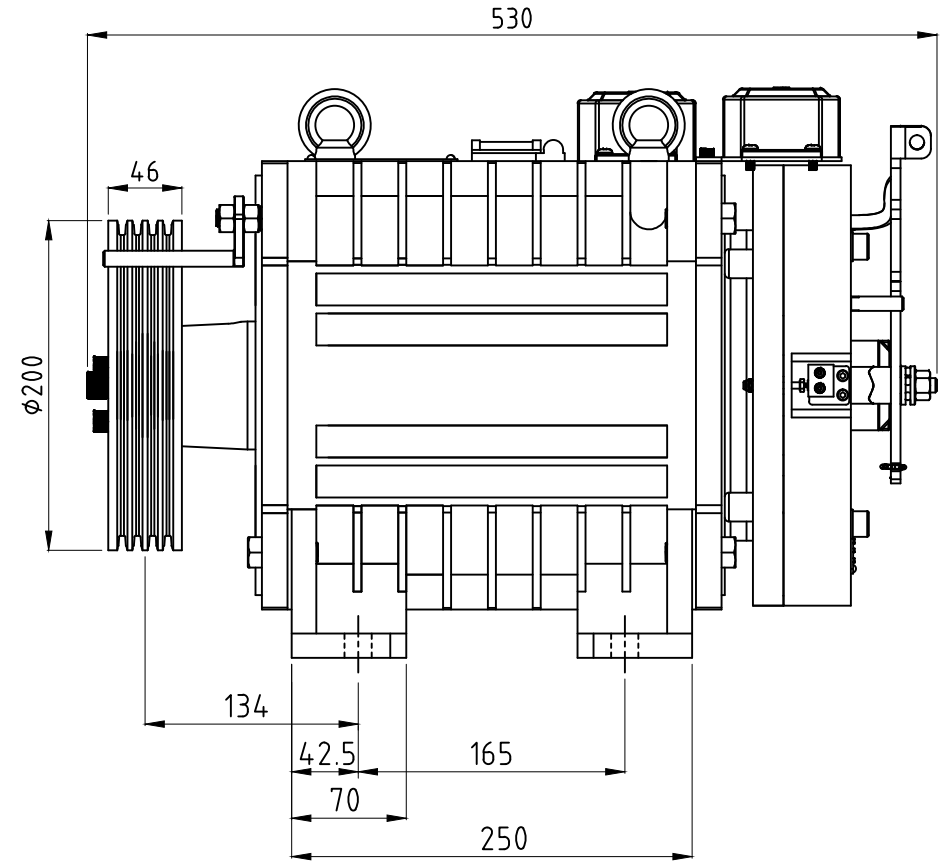
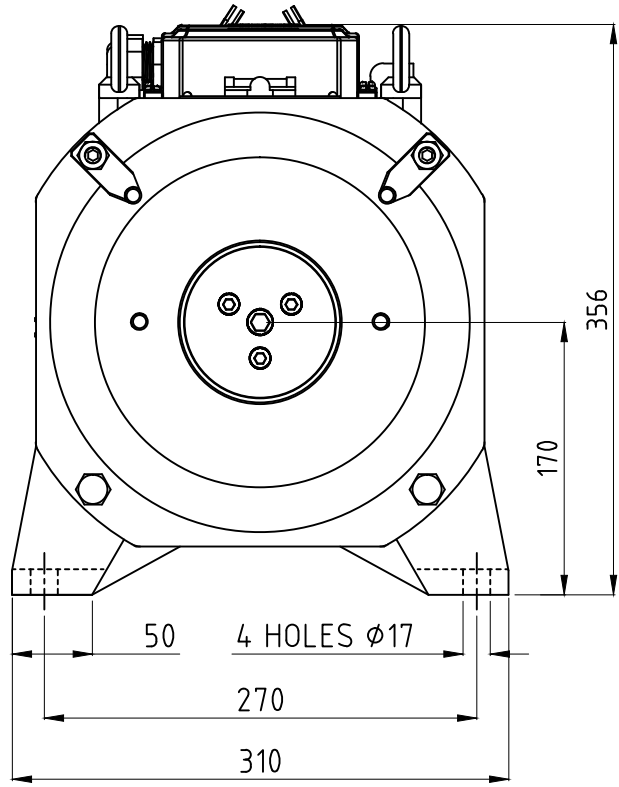

# MODEL-24 BRAKE IS ATTECH IN THIS MODEL.  
 # ALL DIMINTIONS ARE IN MM.

THIS DRAWING IS THE PROPERTY OF **TECTRONICS, RAJKOT**  
 IT SHOULD NOT BE COPIED OR ANY OF IT'S DETAILS DIVULGED  
 TO A THIRD PARTY WITHOUT OUR PRIOR PERMISSION IN WRITING  
 & MUST BE RETURNED TO US ON REQUEST.

MATERIAL :		DIMENSIONS WITH TOLERANCE AND ★ (MARK) ARE CRITICAL.		WEIGHT : 165 KG
RAW PART NO. :		MODEL : RTG 24 P 0806 - 200 (6MM X 4 ROPE)		
		NAME	DATE	TITLE :
		DRN. NISHANT	28/10/18	
		CHKD.		
		APPD.		FINISH PART NO. :
		SCALE : NTS		
		~	FILING	TECTRONICS ENGINEERS RAJKOT
		▽	MACHINING	
		▽▽	FINE MACHINING	
		▽▽▽	GRINDING	
SR.	REVISION DESCRIPTION	DATE	NAME	

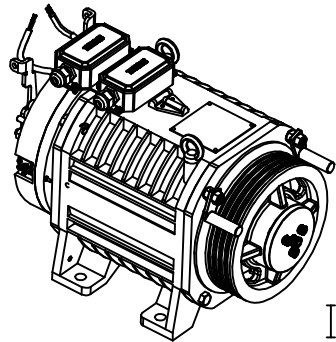
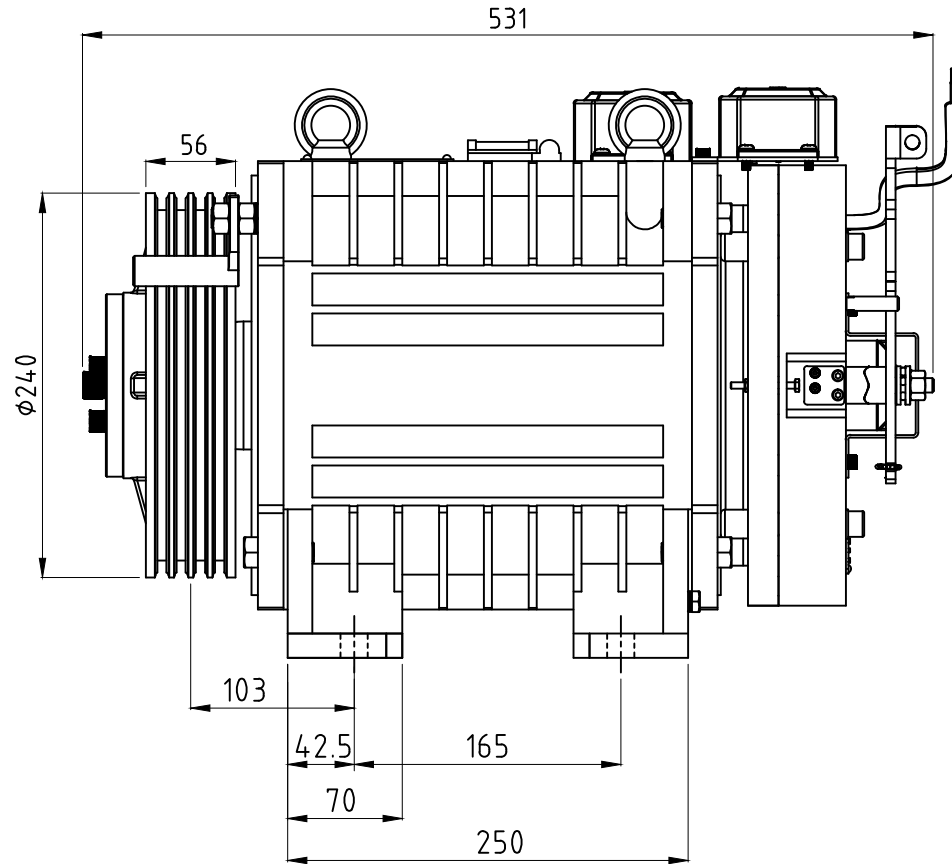
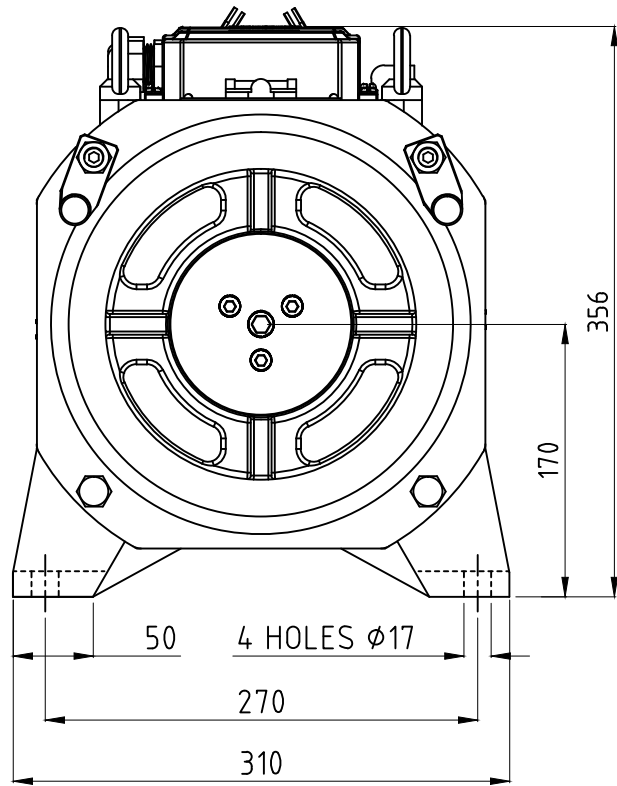

ISO VIEW

# MODEL-24 BRAKE IS ATTECH IN THIS MODEL.  
 # ALL DIMINTIONS ARE IN MM.

THIS DRAWING IS THE PROPERTY OF **TECTRONICS, RAJKOT**  
 IT SHOULD NOT BE COPIED OR ANY OF IT'S DETAILS DIVULGED  
 TO A THIRD PARTY WITHOUT OUR PRIOR PERMISSION IN WRITING  
 & MUST BE RETURNED TO US ON REQUEST.

MATERIAL :		DIMENSIONS WITH TOLERANCE AND ★ (MARK) ARE CRITICAL.		WEIGHT : 165 KG
RAW PART NO. :		MODEL : RTG 24P 0806 - 240 (8 MM X 4 ROPE)		
		NAME	DATE	TITLE :
		DRN. NISHANT	28/10/18	
		CHKD.		
		APPD.		FINISH PART NO. :
		SCALE : NTS		
		~	FILING	<b>TECTRONICS ENGINEERS</b> <b>RAJKOT</b>
		▽	MACHINING	
		▽▽	FINE MACHINING	
		▽▽▽	GRINDING	
SR.	REVISION DESCRIPTION	DATE	NAME	

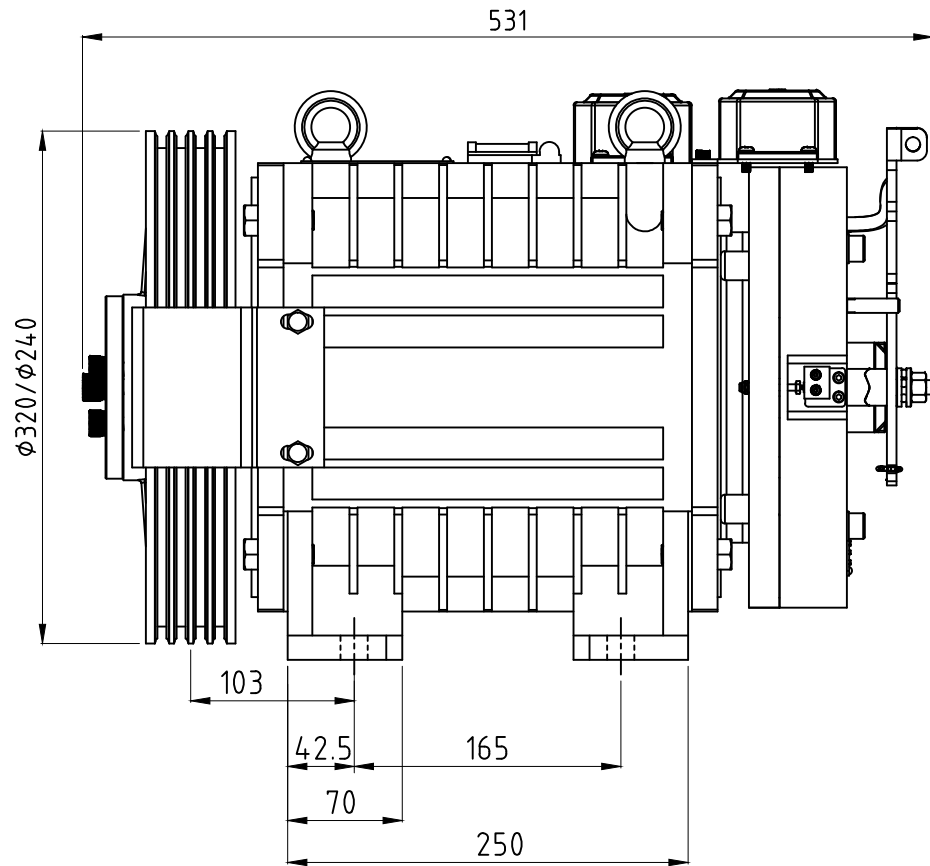
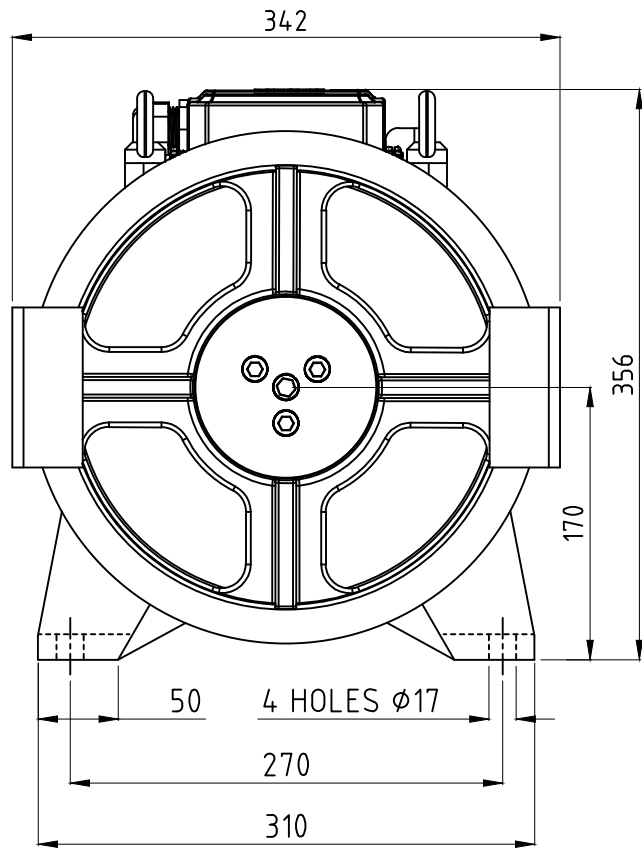

Dimensions in mm

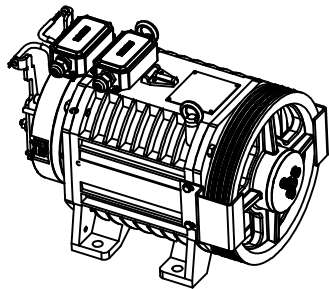

ISO VIEW

# MODEL-24 BRAKE IS ATTECH IN THIS MODEL.

# ALL DIMINTIONS ARE IN MM.

THIS DRAWING IS THE PROPERTY OF **TECTRONICS, RAJKOT**  
IT SHOULD NOT BE COPIED OR ANY OF IT'S DETAILS DIVULGED  
TO A THIRD PARTY WITHOUT OUR PRIOR PERMISSION IN WRITING  
& MUST BE RETURNED TO US ON REQUEST.

MATERIAL :		DIMENSIONS WITH TOLERANCE AND ★ (MARK) ARE CRITICAL.		WEIGHT : 165 KG
RAW PART NO. :		MODEL : RTG 24P 0806 - 320 (8 MM X 4 ROPE)		
		NAME	DATE	TITLE :
		DRN. NISHANT	28/10/18	
		CHKD.		
		APPD.		FINISH PART NO. :
		SCALE : NTS		
		~	FILING	SHEET 1 of 1
		▽	MACHINING	
		▽▽	FINE MACHINING	
		▽▽▽	GRINDING	
SR.	REVISION DESCRIPTION	DATE	NAME	

**LAYOUT**

**TECTRONICS ENGINEERS**  
**RAJKOT**

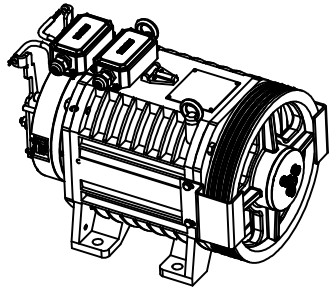
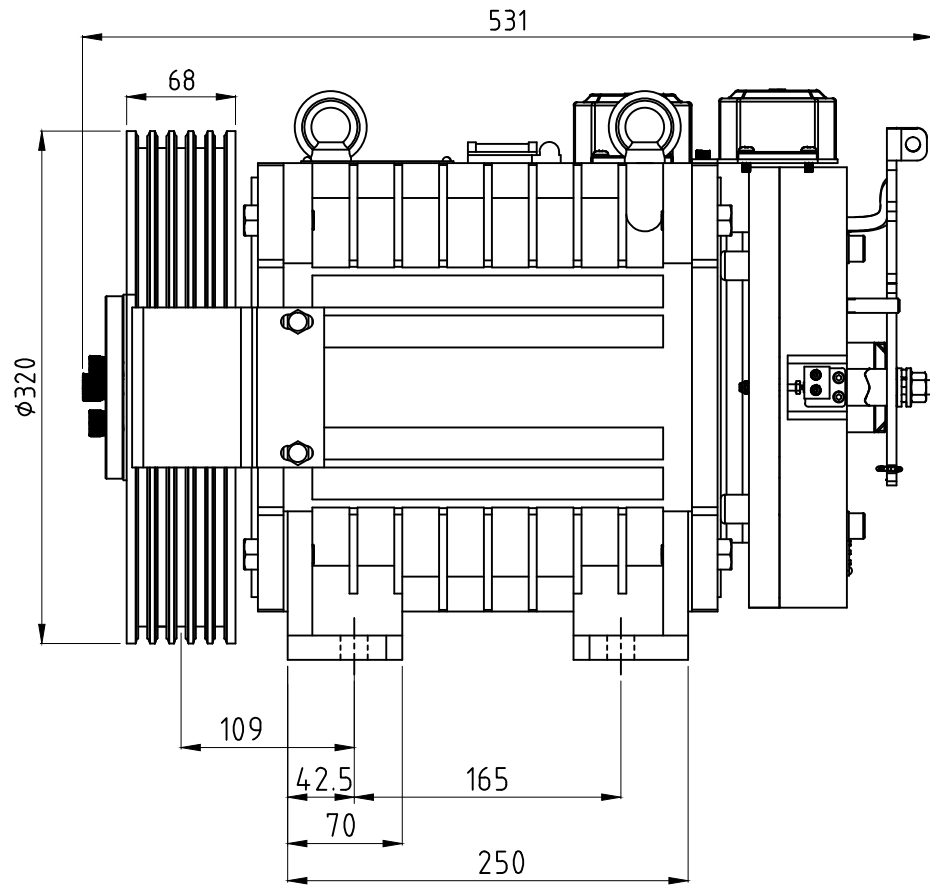
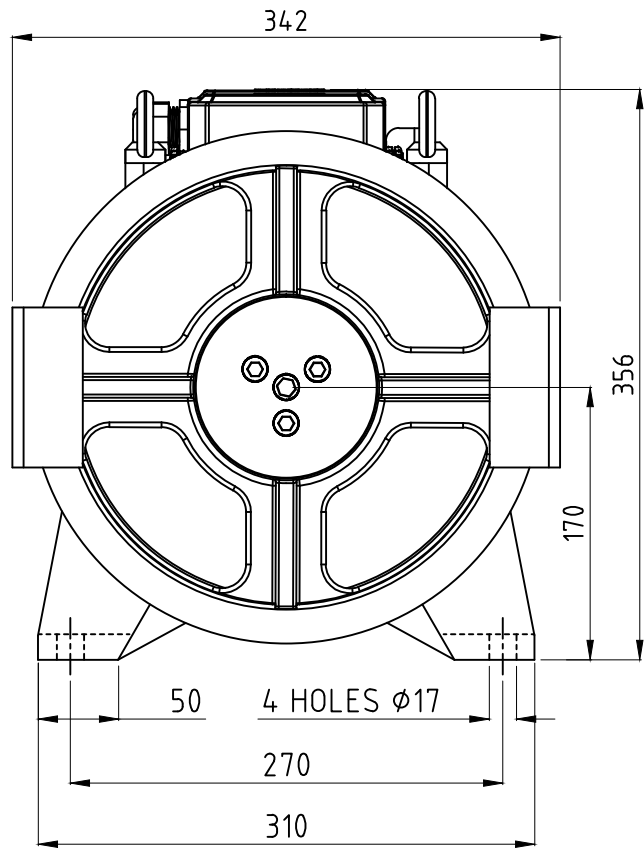

ISO VIEW

# MODEL-24 BRAKE IS ATTECH IN THIS MODEL.  
 # ALL DIMINTIONS ARE IN MM.

THIS DRAWING IS THE PROPERTY OF **TECTRONICS, RAJKOT**  
 IT SHOULD NOT BE COPIED OR ANY OF IT'S DETAILS DIVULGED  
 TO A THIRD PARTY WITHOUT OUR PRIOR PERMISSION IN WRITING  
 & MUST BE RETURNED TO US ON REQUEST.

MATERIAL :		DIMENSIONS WITH TOLERANCE AND ★ (MARK) ARE CRITICAL. WEIGHT : 165 KG	
RAW PART NO. :		MODEL : RTG 24 P 0806 - 320 (8 MM X 5 ROPE)	
	NAME	DATE	TITLE :
	DRN. NISHANT	28/10/18	
	CHKD.		
	APPD.		FINISH PART NO. :
	SCALE : NTS		
	~	FILING	SHEET 1 of 1
	▽	MACHINING	
	▽▽	FINE MACHINING	
	▽▽▽	GRINDING	
SR.	REVISION DESCRIPTION	DATE	NAME

**LAYOUT**

**TECTRONICS ENGINEERS**  
**RAJKOT**

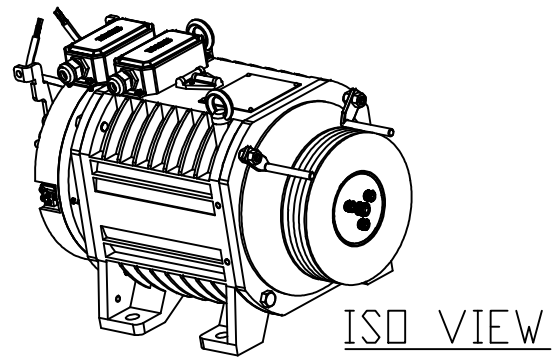
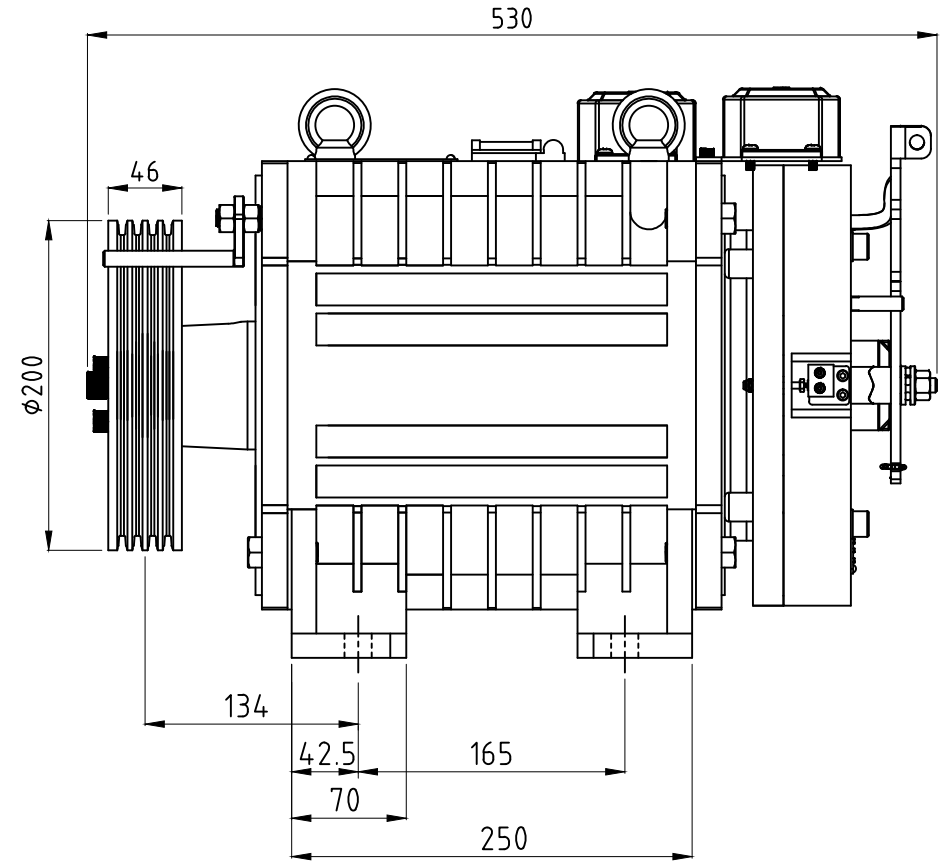
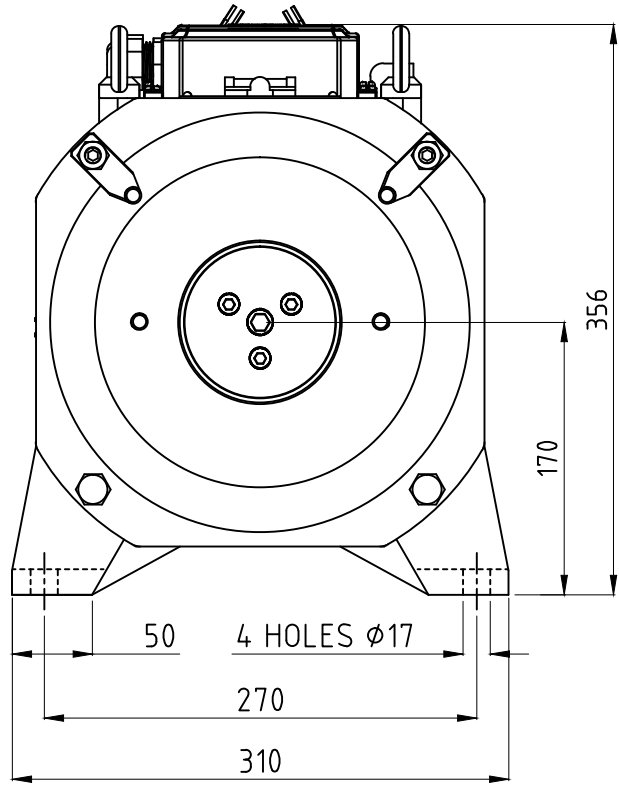

# MODEL-24 BRAKE IS ATTECH IN THIS MODEL.  
 # ALL DIMINTIONS ARE IN MM.

THIS DRAWING IS THE PROPERTY OF **TECTRONICS, RAJKOT**  
 IT SHOULD NOT BE COPIED OR ANY OF IT'S DETAILS DIVULGED  
 TO A THIRD PARTY WITHOUT OUR PRIOR PERMISSION IN WRITING  
 & MUST BE RETURNED TO US ON REQUEST.

MATERIAL :		DIMENSIONS WITH TOLERANCE AND ★ (MARK) ARE CRITICAL.		WEIGHT : 165 KG
RAW PART NO. :		MODEL : RTG 24 P 0808 - 200 (6MM X 4 ROPE)		
		NAME	DATE	TITLE :
		DRN. NISHANT	28/10/18	
		CHKD.		
		APPD.		FINISH PART NO. :
		SCALE : NTS		
		~	FILING	TECTRONICS ENGINEERS RAJKOT
		▽	MACHINING	
		▽▽	FINE MACHINING	
		▽▽▽	GRINDING	
SR.	REVISION DESCRIPTION	DATE	NAME	

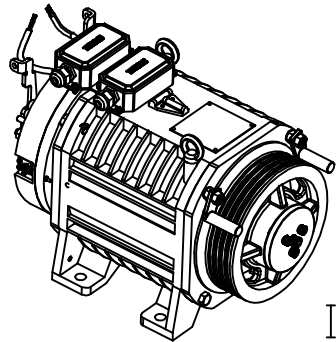
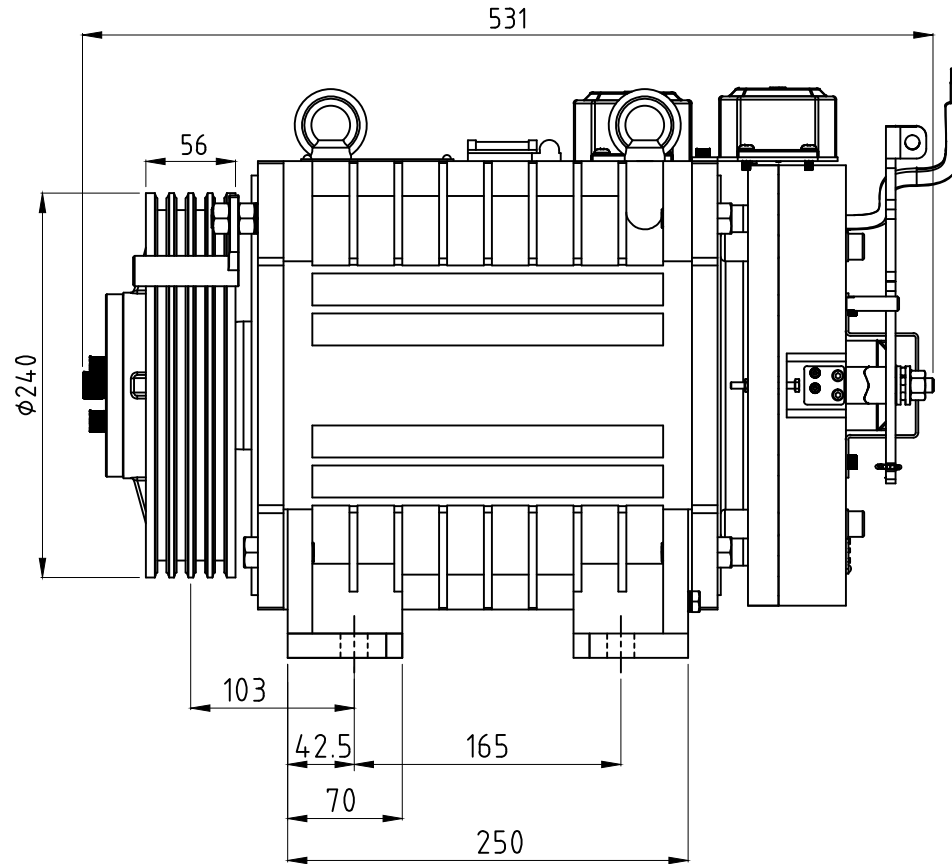
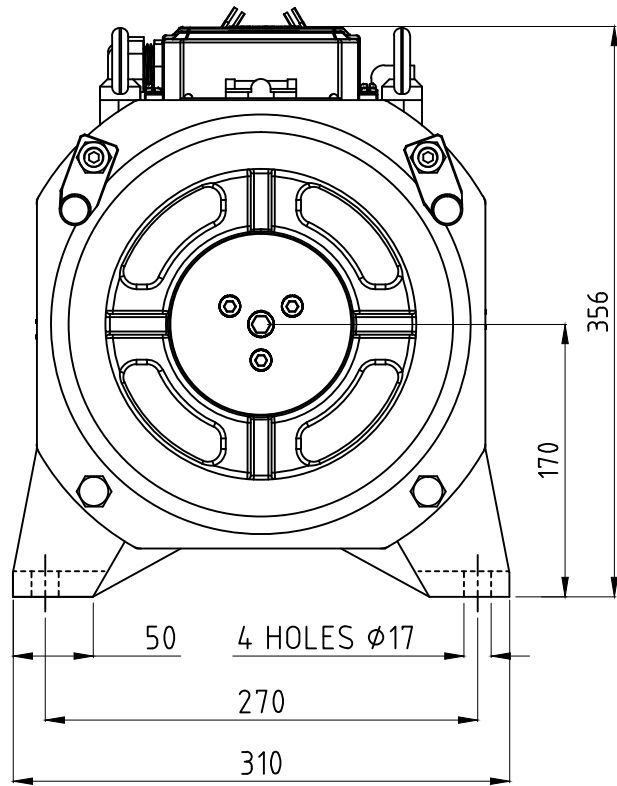

ISO VIEW

# MODEL-24 BRAKE IS ATTECH IN THIS MODEL.  
 # ALL DIMINTIONS ARE IN MM.

THIS DRAWING IS THE PROPERTY OF **TECTRONICS, RAJKOT**  
 IT SHOULD NOT BE COPIED OR ANY OF IT'S DETAILS DIVULGED  
 TO A THIRD PARTY WITHOUT OUR PRIOR PERMISSION IN WRITING  
 & MUST BE RETURNED TO US ON REQUEST.

MATERIAL :		DIMENSIONS WITH TOLERANCE AND ★ (MARK) ARE CRITICAL.		WEIGHT : 165 KG
RAW PART NO. :		MODEL : RTG 24P 0808 - 240 (8 MM X 4 ROPE)		
		NAME	DATE	TITLE :
		DRN. NISHANT	28/10/18	
		CHKD.		
		APPD.		FINISH PART NO. :
		SCALE : NTS		
		~	FILING	SHEET 1 of 1
		▽	MACHINING	
		▽▽	FINE MACHINING	
		▽▽▽	GRINDING	
SR.	REVISION DESCRIPTION	DATE	NAME	

**LAYOUT**

**TECTRONICS ENGINEERS**  
**RAJKOT**



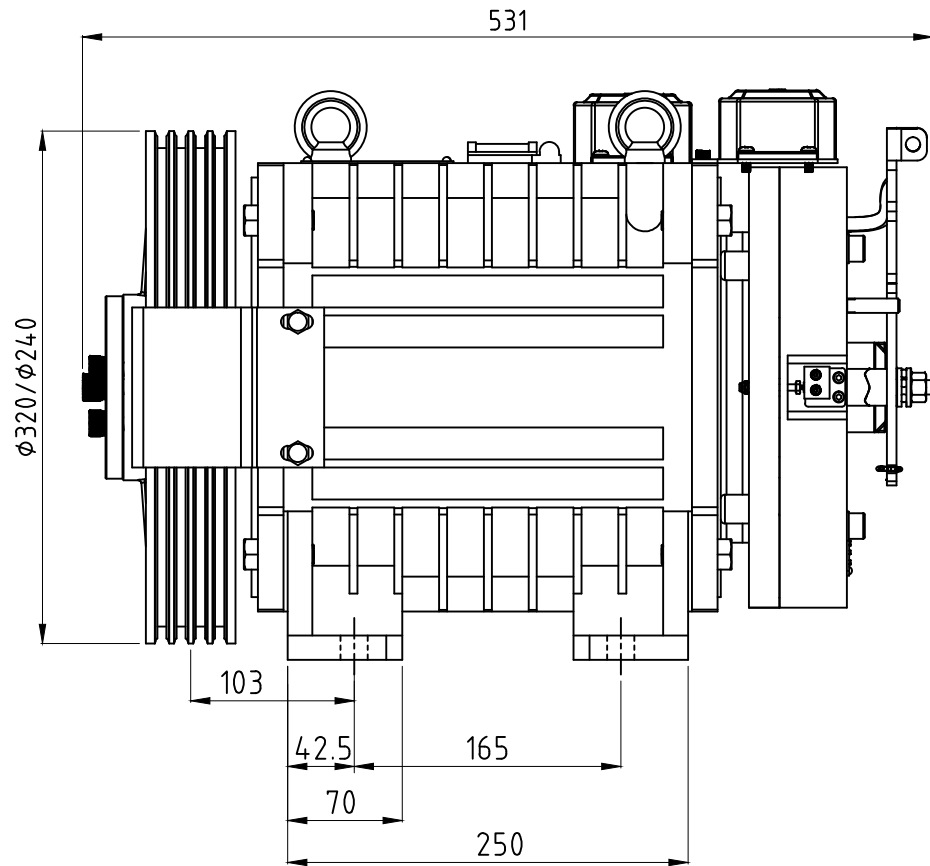
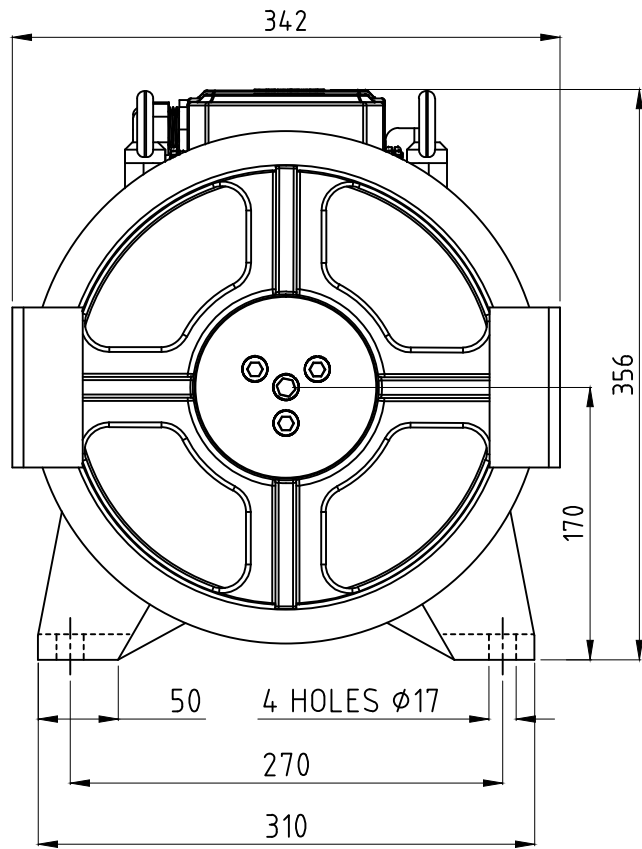

Dimensions in mm

# MODEL-24 BRAKE IS ATTECH IN THIS MODEL.

# ALL DIMINTIONS ARE IN MM.

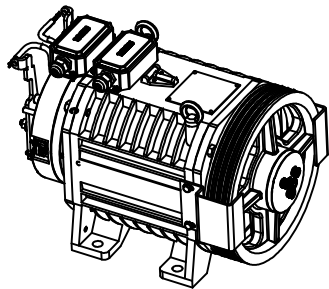

ISO VIEW

THIS DRAWING IS THE PROPERTY OF **TECTRONICS, RAJKOT**  
IT SHOULD NOT BE COPIED OR ANY OF IT'S DETAILS DIVULGED  
TO A THIRD PARTY WITHOUT OUR PRIOR PERMISSION IN WRITING  
& MUST BE RETURNED TO US ON REQUEST.

MATERIAL :		DIMENSIONS WITH TOLERANCE AND ★ (MARK) ARE CRITICAL.		WEIGHT : 165 KG
RAW PART NO. :		MODEL : RTG 24P 0808 - 320 (8 MM X 4 ROPE)		
		NAME	DATE	TITLE :
		DRN. NISHANT	28/10/18	
		CHKD.		
		APPD.		FINISH PART NO. :
		SCALE : NTS		
		~	FILING	TECTRONICS ENGINEERS RAJKOT
		▽	MACHINING	
		▽▽	FINE MACHINING	
		▽▽▽	GRINDING	
SR.	REVISION DESCRIPTION	DATE	NAME	

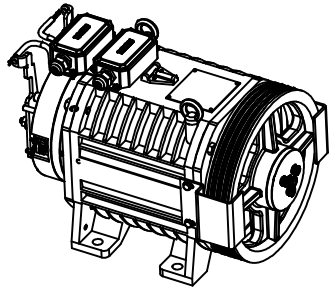
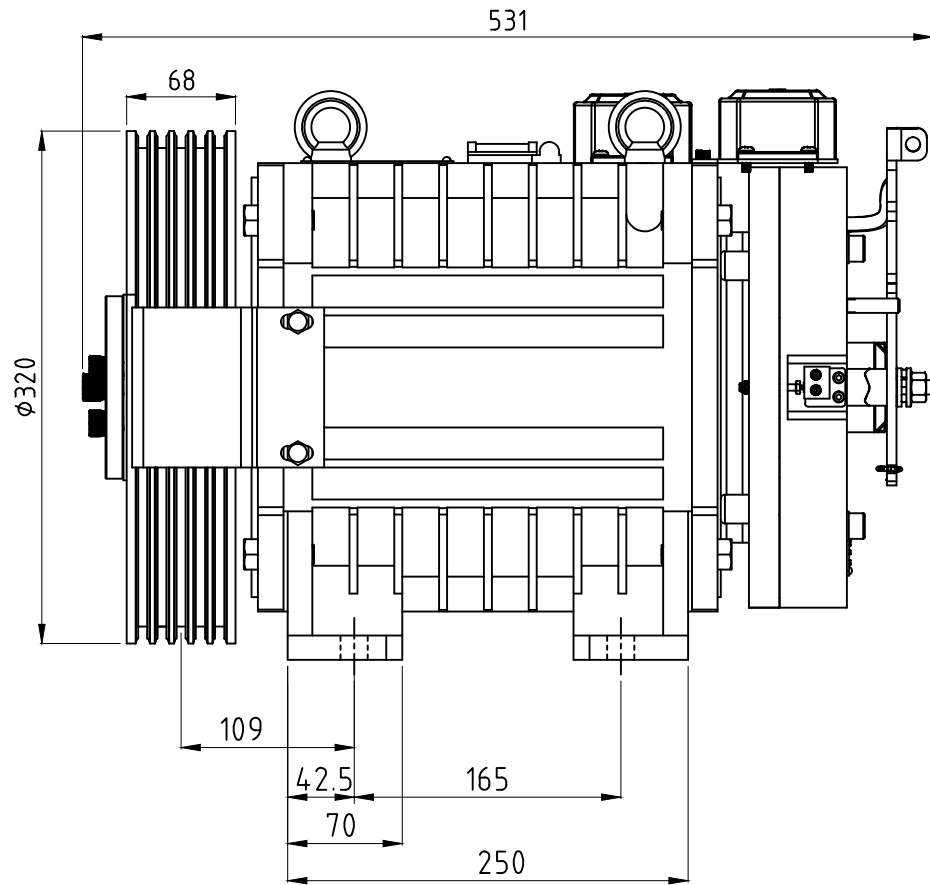
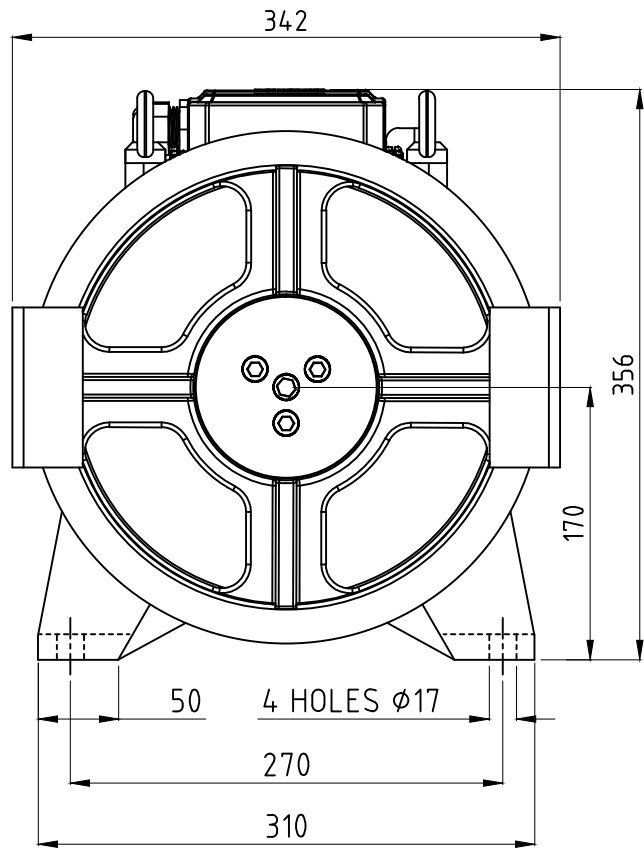

ISO VIEW

# MODEL-24 BRAKE IS ATTECH IN THIS MODEL.  
 # ALL DIMINTIONS ARE IN MM.

THIS DRAWING IS THE PROPERTY OF **TECTRONICS, RAJKOT**  
 IT SHOULD NOT BE COPIED OR ANY OF IT'S DETAILS DIVULGED  
 TO A THIRD PARTY WITHOUT OUR PRIOR PERMISSION IN WRITING  
 & MUST BE RETURNED TO US ON REQUEST.

MATERIAL :		DIMENSIONS WITH TOLERANCE AND ★ (MARK) ARE CRITICAL.		WEIGHT : 165 KG
RAW PART NO. :		MODEL : RTG 24 P 0808 - 320 (8 MM X 5 ROPE)		
		NAME	DATE	TITLE :
		DRN. NISHANT	28/10/18	
		CHKD.		
		APPD.		FINISH PART NO. :
		SCALE : NTS		
		~	FILING	SHEET 1 of 1
		▽	MACHINING	
		▽▽	FINE MACHINING	
		▽▽▽	GRINDING	
SR.	REVISION DESCRIPTION	DATE	NAME	

**LAYOUT**

**TECTRONICS ENGINEERS**  
**RAJKOT**



*Power of Smart Engineering*

# **RTG Series**

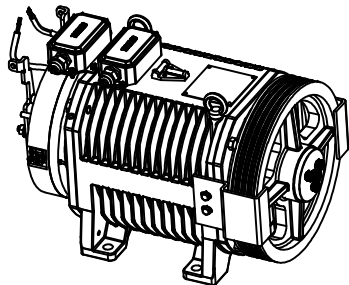
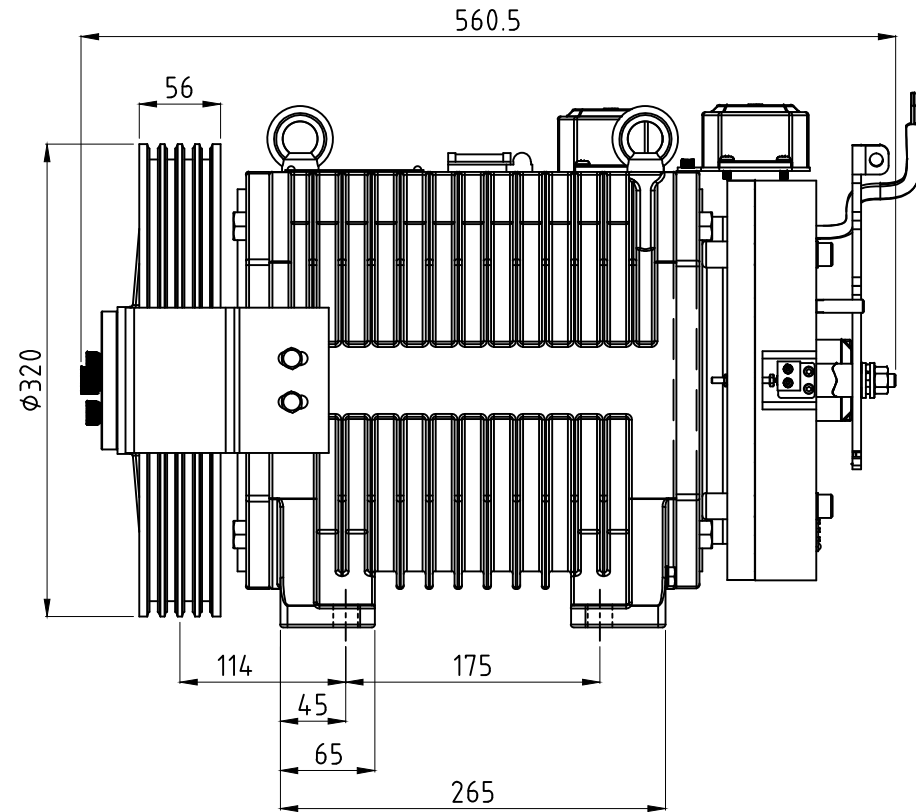
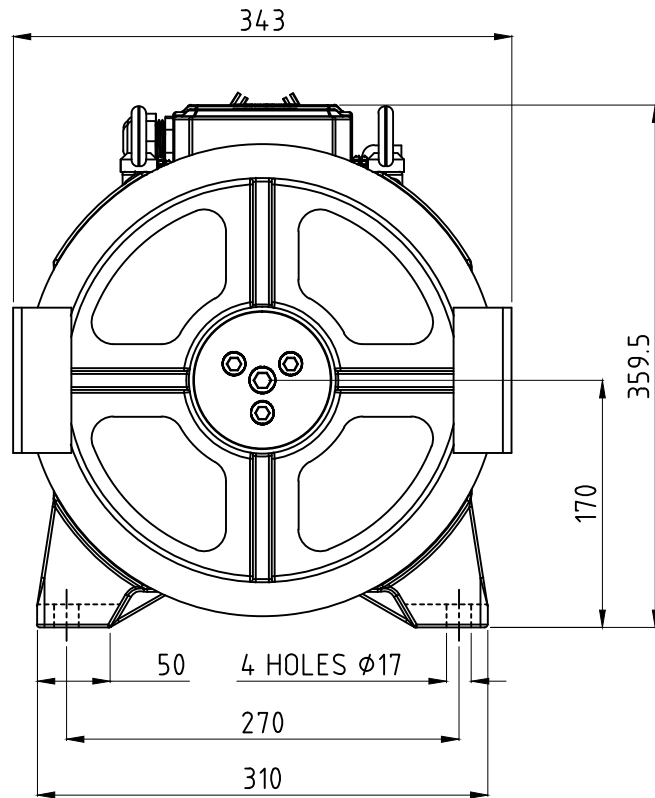

ISO VIEW

# MODEL-24 BRAKE IS ATTECH IN THIS MODEL.  
 # ALL DIMINTIONS ARE IN MM.

MATERIAL :		DIMENSIONS WITH TOLERANCE AND ★ (MARK) ARE CRITICAL.		WEIGHT : 163 KG
RAW PART NO. :		MODEL : RTG 0808 - 320 (8 MM X 4 ROPE)		
		NAME	DATE	TITLE : <b>LAYOUT</b>
		DRN. NISHANT	28/10/'18	
		CHKD.		
		APPD.		FINISH PART NO. :
		SCALE : NTS		
		~	FILING	<b>TECTRONICS ENGINEERS RAJKOT</b>
		▽	MACHINING	
		▽▽	FINE MACHINING	
		▽▽▽	GRINDING	
SR.	REVISION DESCRIPTION	DATE	NAME	

THIS DRAWING IS THE PROPERTY OF **TECTRONICS, RAJKOT**  
 IT SHOULD NOT BE COPIED OR ANY OF IT'S DETAILS DIVULGED  
 TO A THIRD PARTY WITHOUT OUR PRIOR PERMISSION IN WRITING  
 & MUST BE RETURNED TO US ON REQUEST.

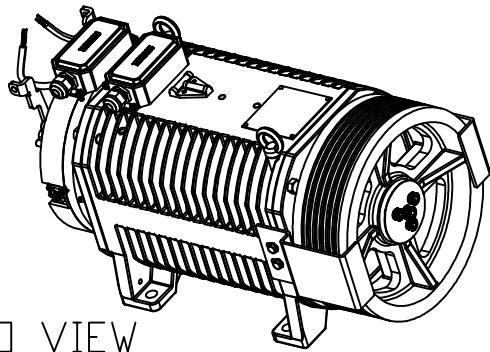
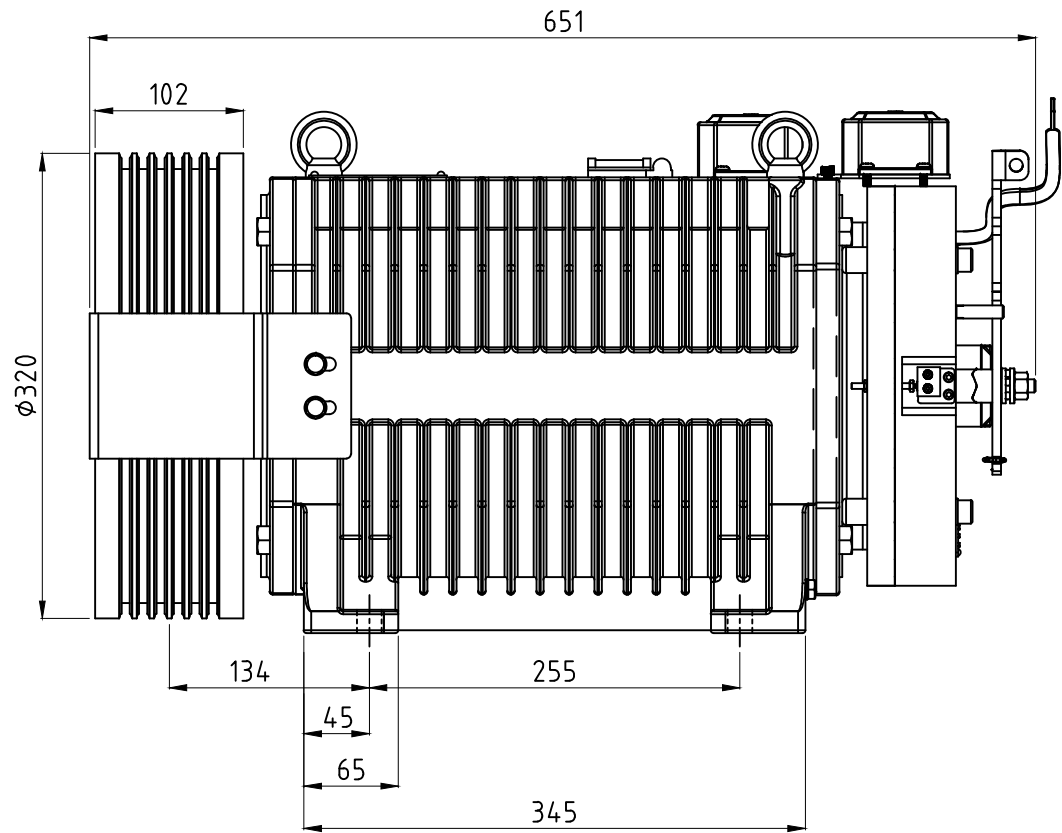
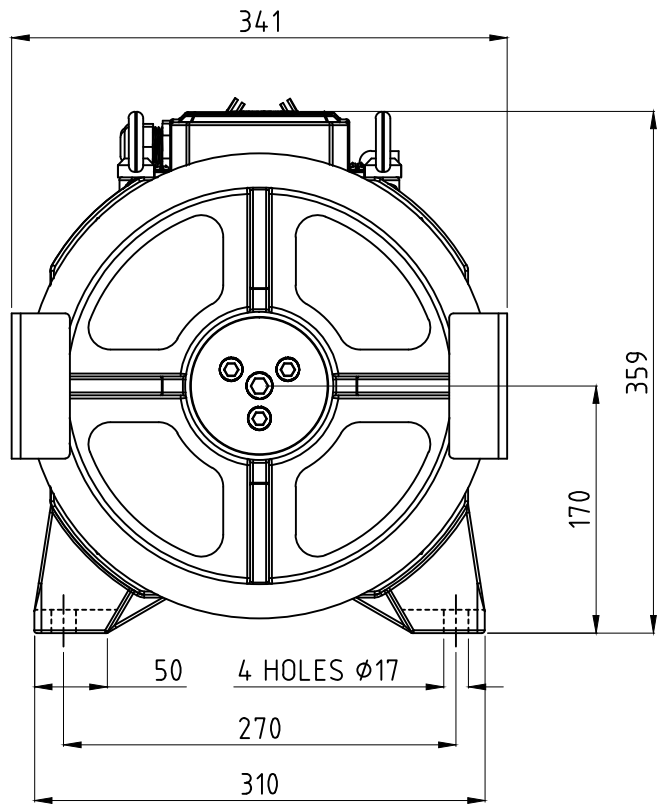

ISO VIEW

# MODEL-24 BRAKE IS ATTECH IN THIS MODEL.  
 # ALL DIMINTIONS ARE IN MM.

MATERIAL :		DIMENSIONS WITH TOLERANCE AND ★ (MARK) ARE CRITICAL.		WEIGHT : 199 KG
RAW PART NO. :		MODEL : RTG 1010 - 320 (8 MM X 6 ROPE)		
		NAME	DATE	TITLE : <b>LAYOUT</b>
		DRN. NISHANT	28/10/'18	
		CHKD.		
		APPD.		
		SCALE : NTS		FINISH PART NO. :
		~	FILING	SHEET 1 of 1
		▽	MACHINING	
		▽▽	FINE MACHINING	
		▽▽▽	GRINDING	
SR.	REVISION DESCRIPTION	DATE	NAME	

THIS DRAWING IS THE PROPERTY OF **TECTRONICS, RAJKOT**  
 IT SHOULD NOT BE COPIED OR ANY OF IT'S DETAILS DIVULGED  
 TO A THIRD PARTY WITHOUT OUR PRIOR PERMISSION IN WRITING  
 & MUST BE RETURNED TO US ON REQUEST.

**TECTRONICS ENGINEERS**  
**RAJKOT**

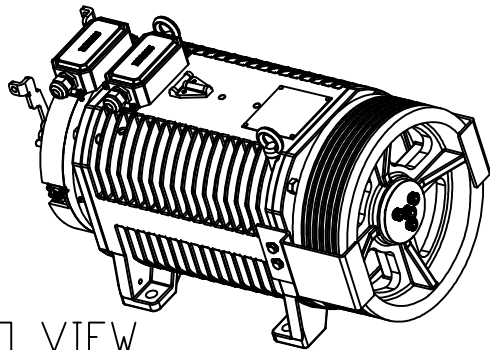
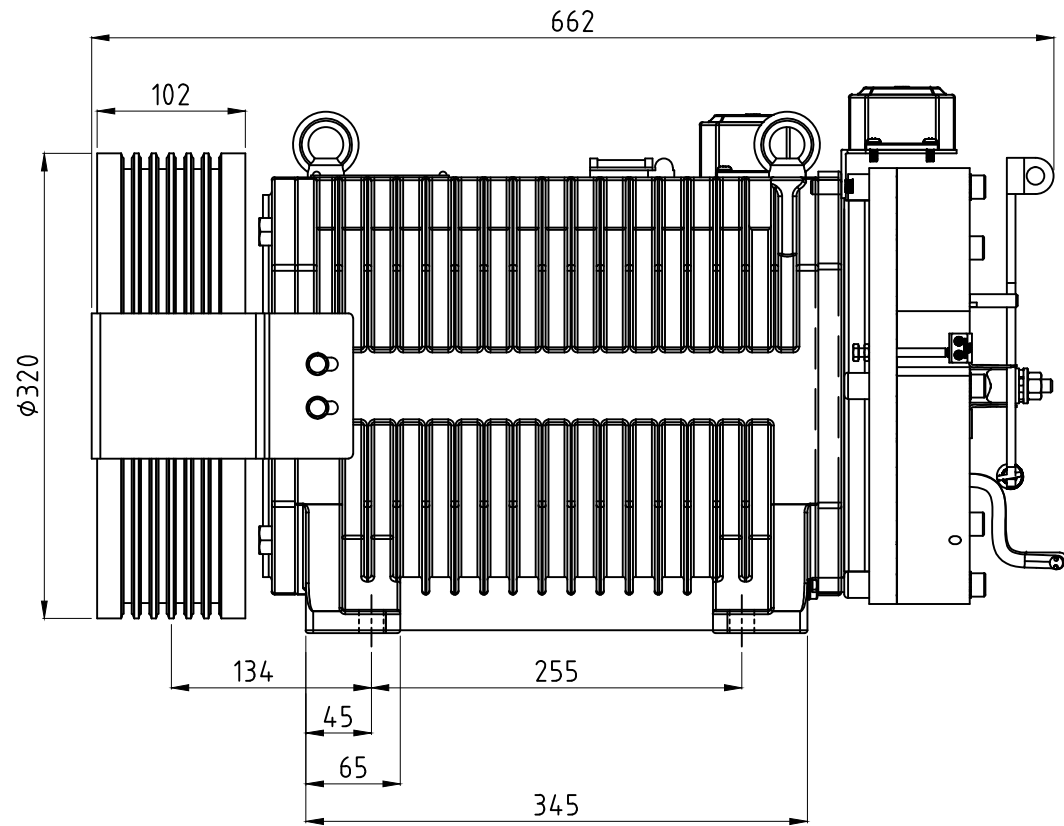
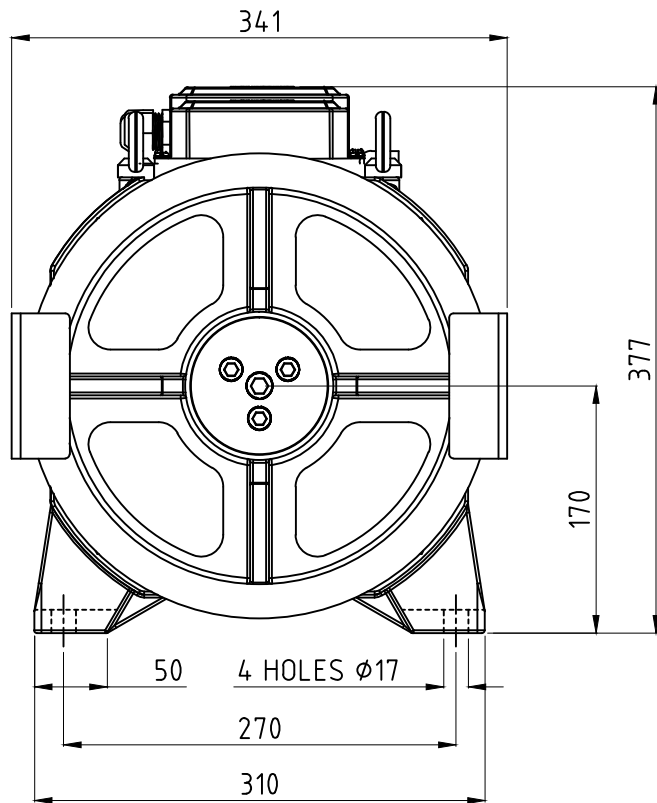

ISO VIEW

# MODEL-34 BRAKE IS ATTECH IN THIS MODEL.  
 # ALL DIMINTIONS ARE IN MM.

MATERIAL :		DIMENSIONS WITH TOLERANCE AND ★ (MARK) ARE CRITICAL.		WEIGHT : 225 KG
RAW PART NO. :		MODEL : RTG 1013 - 320 (8 MM X 6 ROPE)		
		NAME	DATE	TITLE : <b>LAYOUT</b>
		DRN. NISHANT	28/10/'18	
		CHKD.		
		APPD.		FINISH PART NO. :
		SCALE : NTS		
		~	FILING	<b>TECTRONICS ENGINEERS RAJKOT</b>
		▽	MACHINING	
		▽▽	FINE MACHINING	
		▽▽▽	GRINDING	
SR.	REVISION DESCRIPTION	DATE	NAME	

THIS DRAWING IS THE PROPERTY OF **TECTRONICS, RAJKOT**  
 IT SHOULD NOT BE COPIED OR ANY OF IT'S DETAILS DIVULGED  
 TO A THIRD PARTY WITHOUT OUR PRIOR PERMISSION IN WRITING  
 & MUST BE RETURNED TO US ON REQUEST.

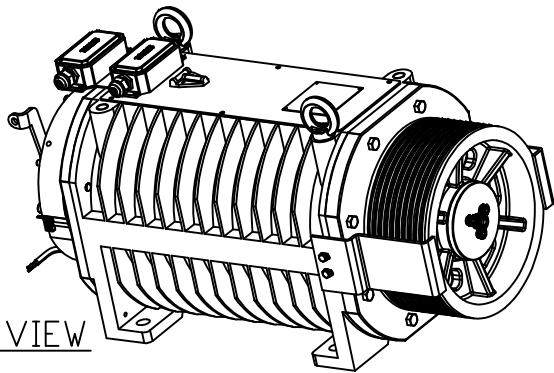
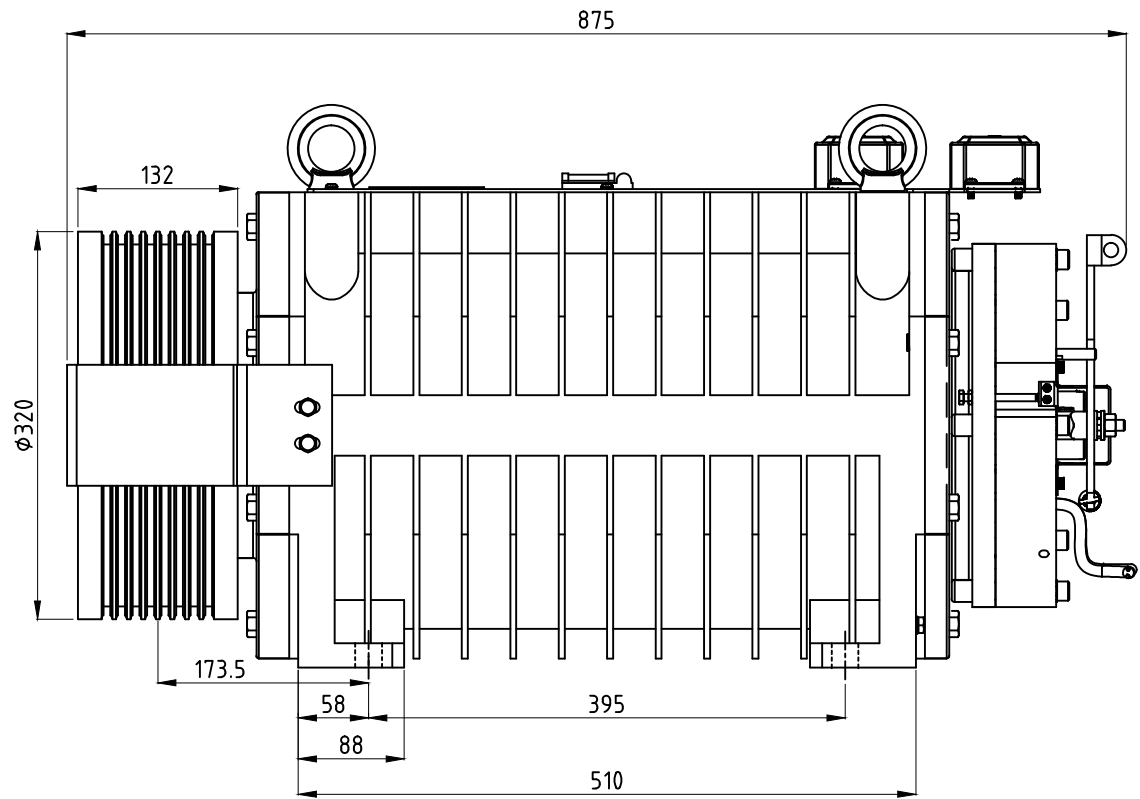
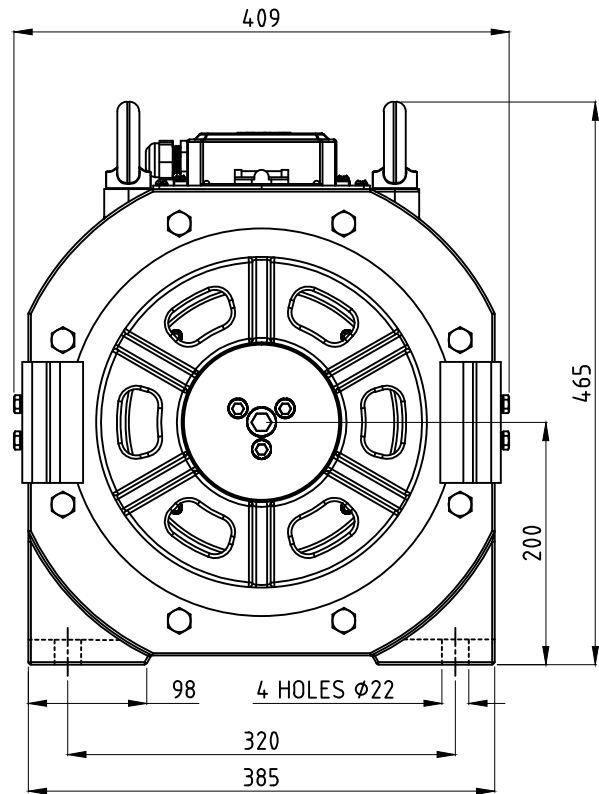

ISO VIEW

# MODEL-34 BRAKE IS ATTECH IN THIS MODEL.  
 # ALL DIMINTIONS ARE IN MM.

MATERIAL :			DIMENSIONS WITH TOLERANCE AND ★ (MARK) ARE CRITICAL. WEIGHT : 163 KG	
RAW PART NO. :			MODEL : RTG 1616 - 320 (8 MM X 8 ROPE)	
		NAME	DATE	TITLE :
		DRN. NISHANT	28/10/'18	
		CHKD.		
		APPD.		FINISH PART NO. :
		SCALE : NTS		
		~	FILING	<b>TECTRONICS ENGINEERS</b> <b>RAJKOT</b>
		▽	MACHINING	
		▽▽	FINE MACHINING	
		▽▽▽	GRINDING	
SR.	REVISION DESCRIPTION	DATE	NAME	

THIS DRAWING IS THE PROPERTY OF TECTRONICS, RAJKOT  
 IT SHOULD NOT BE COPIED OR ANY OF IT'S DETAILS DIVULGED  
 TO A THIRD PARTY WITHOUT OUR PRIOR PERMISSION IN WRITING  
 & MUST BE RETURNED TO US ON REQUEST.

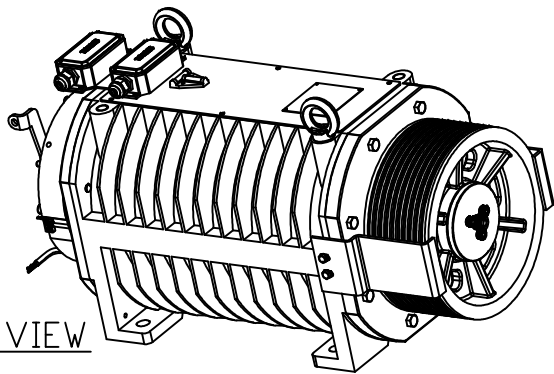
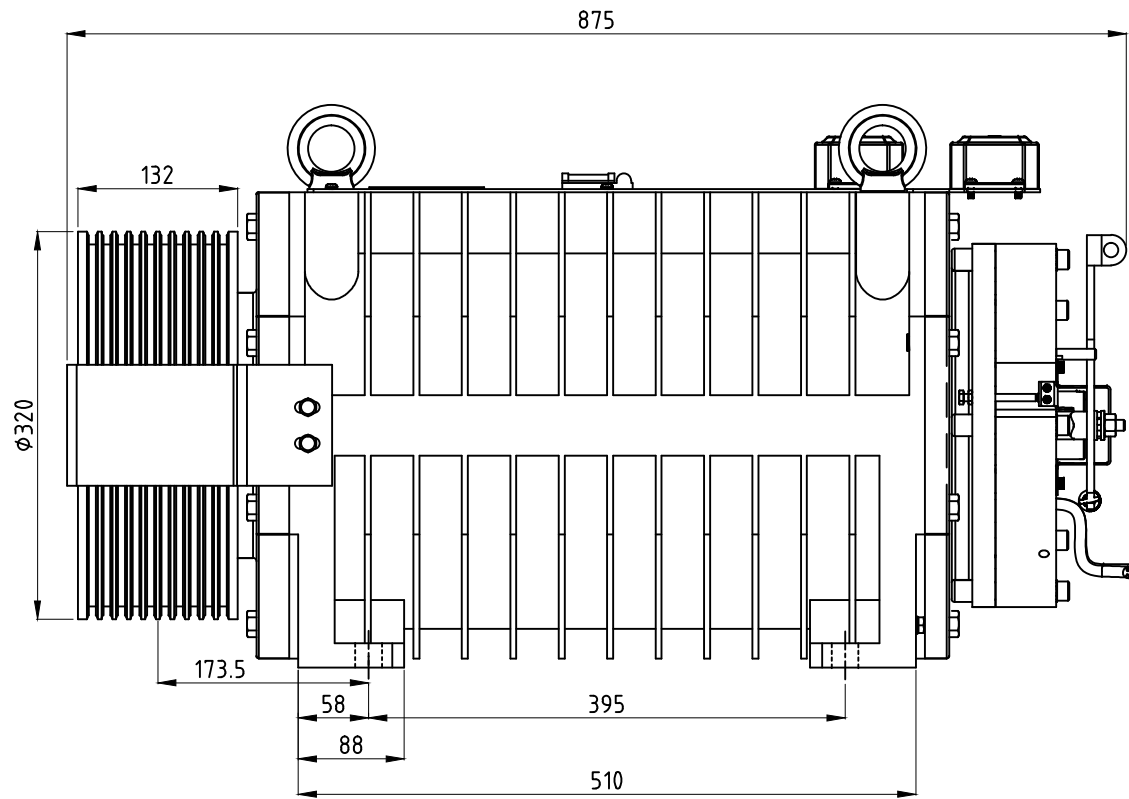
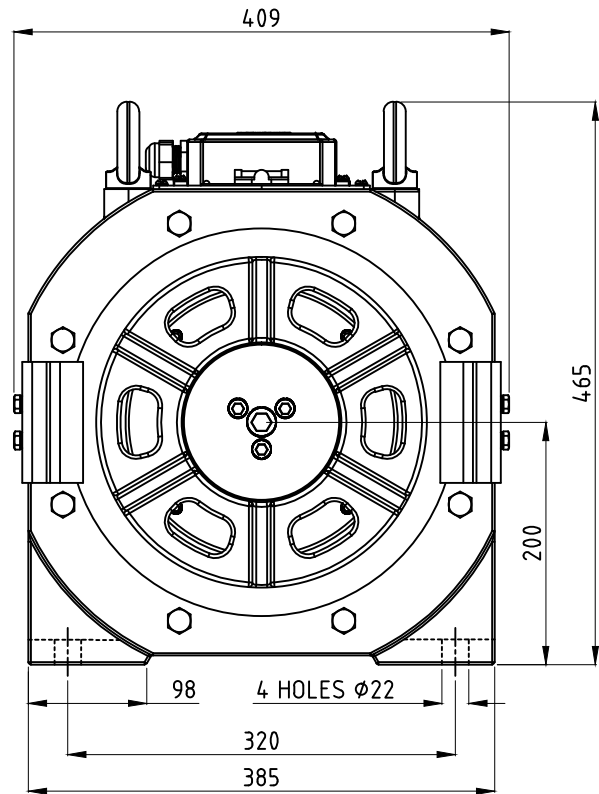

ISO VIEW

# MODEL-34 BRAKE IS ATTACH IN THIS MODEL.  
 # ALL DIMENSIONS ARE IN MM.

MATERIAL :			DIMENSIONS WITH TOLERANCE AND ★ (MARK) ARE CRITICAL. WEIGHT : 163 KG	
RAW PART NO. :			MODEL : RTG 1620 - 320 (8 MM X 10 ROPE)	
		NAME	DATE	TITLE :
		DRN. NISHANT	28/10/18	
		CHKD.		
		APPD.		FINISH PART NO. :
		SCALE : NTS		
		~	FILING	SHEET 1 of 1
		▽	MACHINING	
		▽▽	FINE MACHINING	
		▽▽▽	GRINDING	
SR.	REVISION DESCRIPTION	DATE	NAME	

LAYOUT

**TECTRONICS ENGINEERS  
RAJKOT**

THIS DRAWING IS THE PROPERTY OF TECTRONICS, RAJKOT  
 IT SHOULD NOT BE COPIED OR ANY OF ITS DETAILS DIVULGED  
 TO A THIRD PARTY WITHOUT OUR PRIOR PERMISSION IN WRITING  
 & MUST BE RETURNED TO US ON REQUEST.



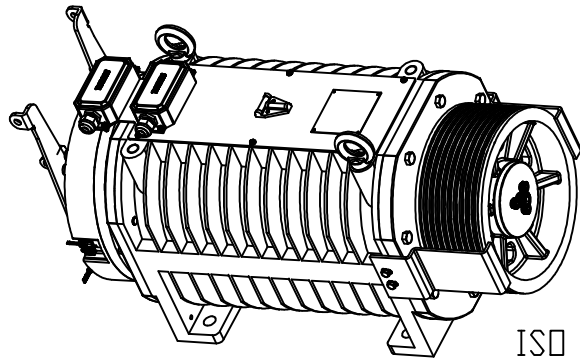
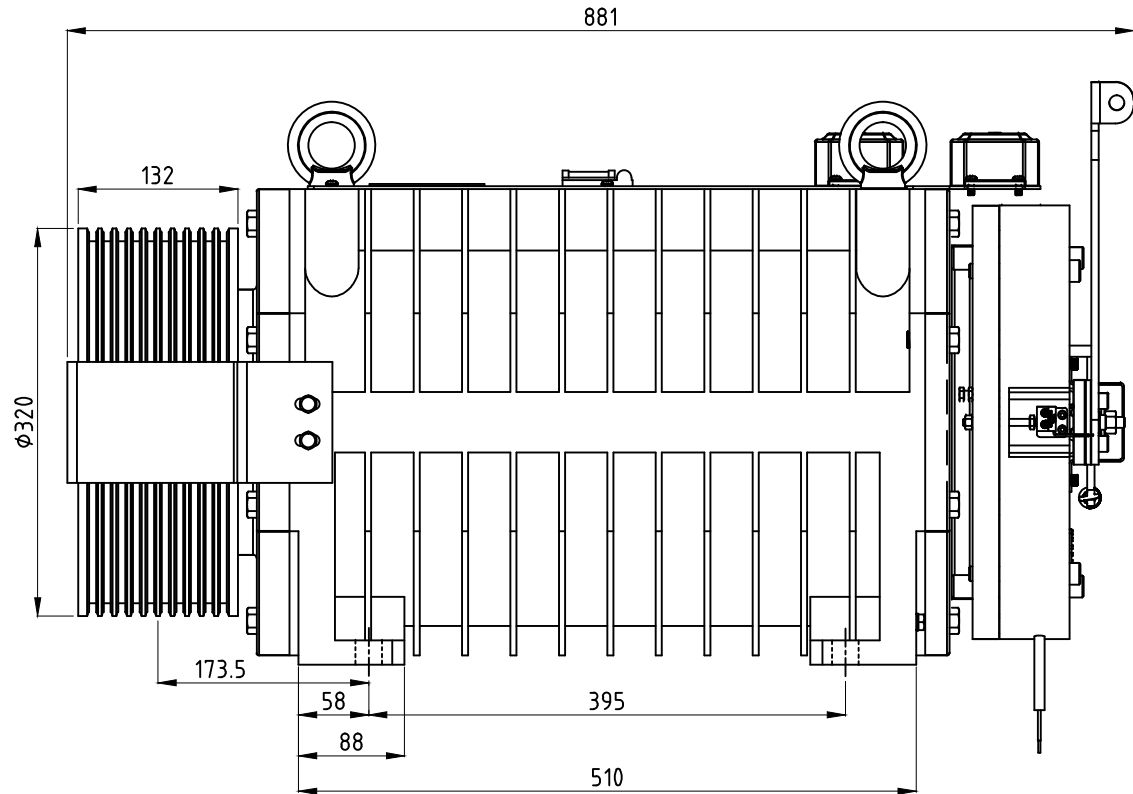
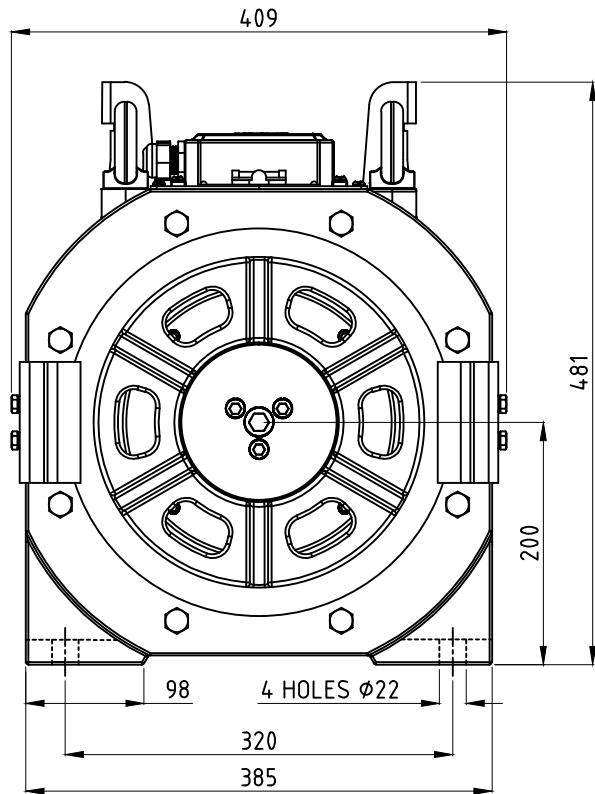

ISO VIEW

# MODEL 2x1400 BRAKE IS ATTECH IN THIS MODEL.  
 # ALL DIMINTIONS ARE IN MM.

MATERIAL :			DIMENSIONS WITH TOLERANCE AND ★ (MARK) ARE CRITICAL. WEIGHT : 163 KG	
RAW PART NO. :			MODEL : RTG 2500 - 320 (8 MM X 10 ROPE)	
		NAME	DATE	TITLE :
		DRN. NISHANT	28/10/'18	
		CHKD.		
		APPD.		FINISH PART NO. :
		SCALE : NTS		
		~	FILING	SHEET 1 of 1
		▽	MACHINING	
		▽▽	FINE MACHINING	
		▽▽▽	GRINDING	
SR.	REVISION DESCRIPTION	DATE	NAME	

**LAYOUT**

**TECTRONICS ENGINEERS**  
**RAJKOT**

THIS DRAWING IS THE PROPERTY OF TECTRONICS, RAJKOT  
 IT SHOULD NOT BE COPIED OR ANY OF IT'S DETAILS DIVULGED  
 TO A THIRD PARTY WITHOUT OUR PRIOR PERMISSION IN WRITING  
 & MUST BE RETURNED TO US ON REQUEST.



*Power of Smart Engineering*

# **TG Series**

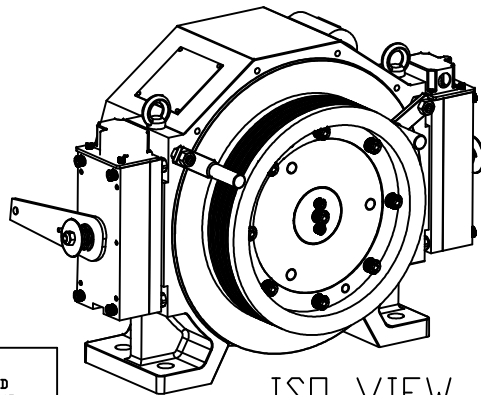
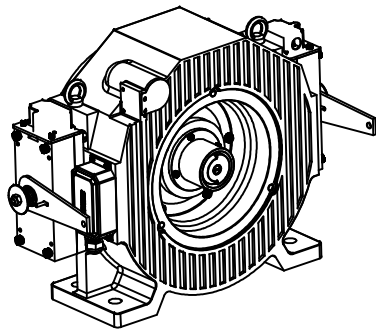
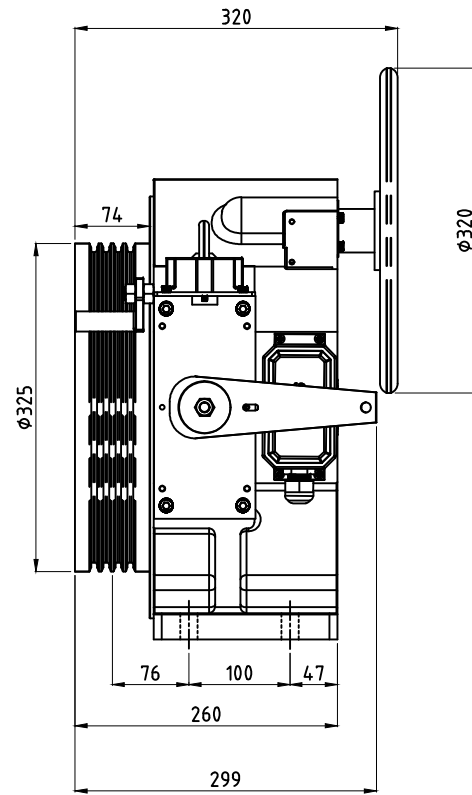
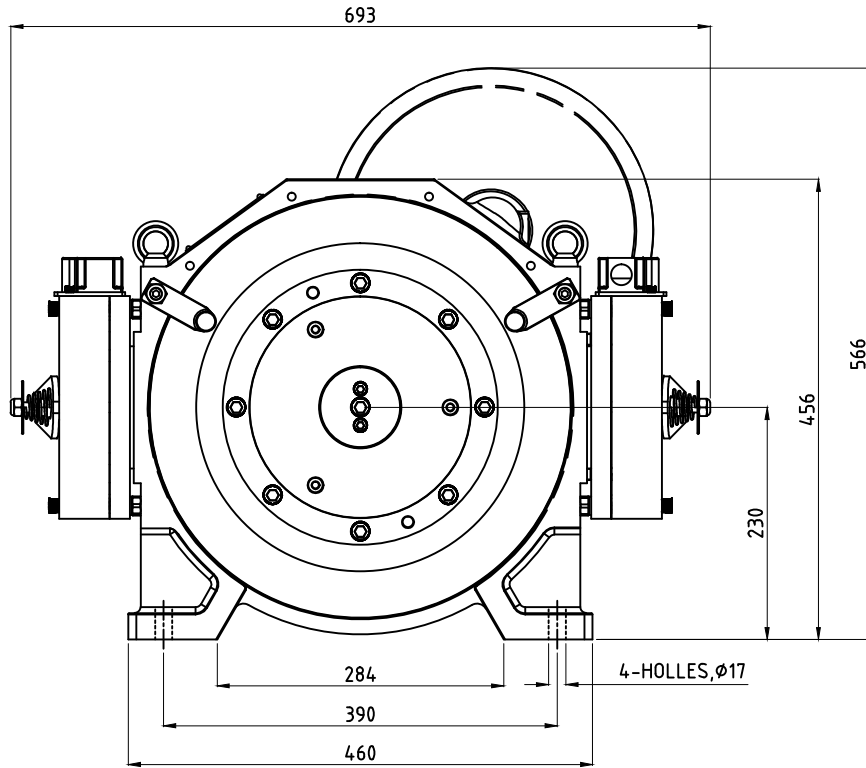

# ALL DIMENTIONS ARE IN MM.

MATERIAL :		DIMENSIONS WITH TOLERANCE AND ★ (MARK) ARE CRITICAL.		WEIGHT : 205 KG
RAW PART NO. :		MODEL : TG-0806 - 325 (8MM X 4 ROPE)		
		NAME	DATE	TITLE :
		DRN. NISHANT	28/10/18	
		CHKD.		
		APPD.		FINISH PART NO. :
		SCALE : NTS		
		~	FILING	SHEET 1 of 1
		▽	MACHINING	
		▽▽	FINE MACHINING	
		▽▽▽	GRINDING	
SR.	REVISION DESCRIPTION	DATE	NAME	

THIS DRAWING IS THE PROPERTY OF **TECTRONICS, RAJKOT**  
IT SHOULD NOT BE COPIED OR ANY OF IT'S DETAILS DIVULGED  
TO A THIRD PARTY WITHOUT OUR PRIOR PERMISSION IN WRITING  
& MUST BE RETURNED TO US ON REQUEST.

**LAYOUT**

**TECTRONICS ENGINEERS**  
**RAJKOT**

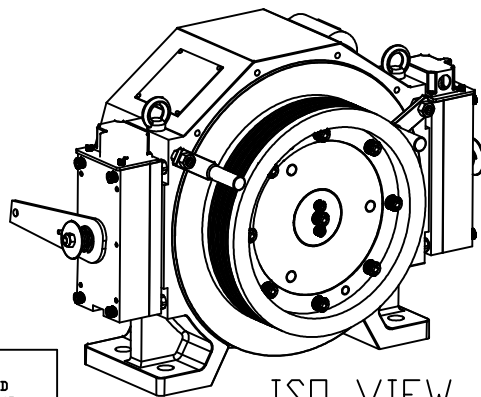
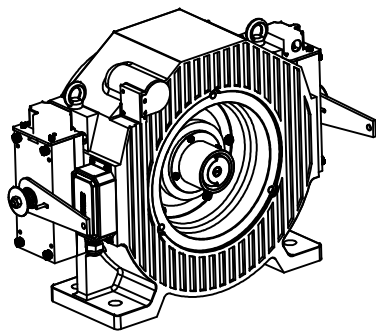
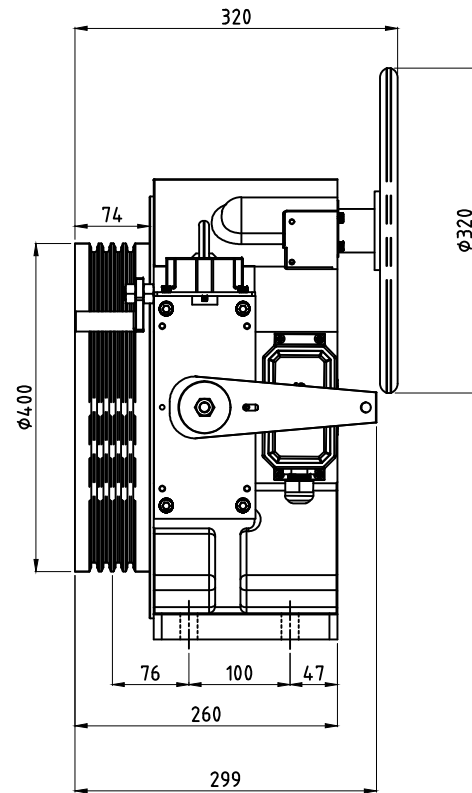
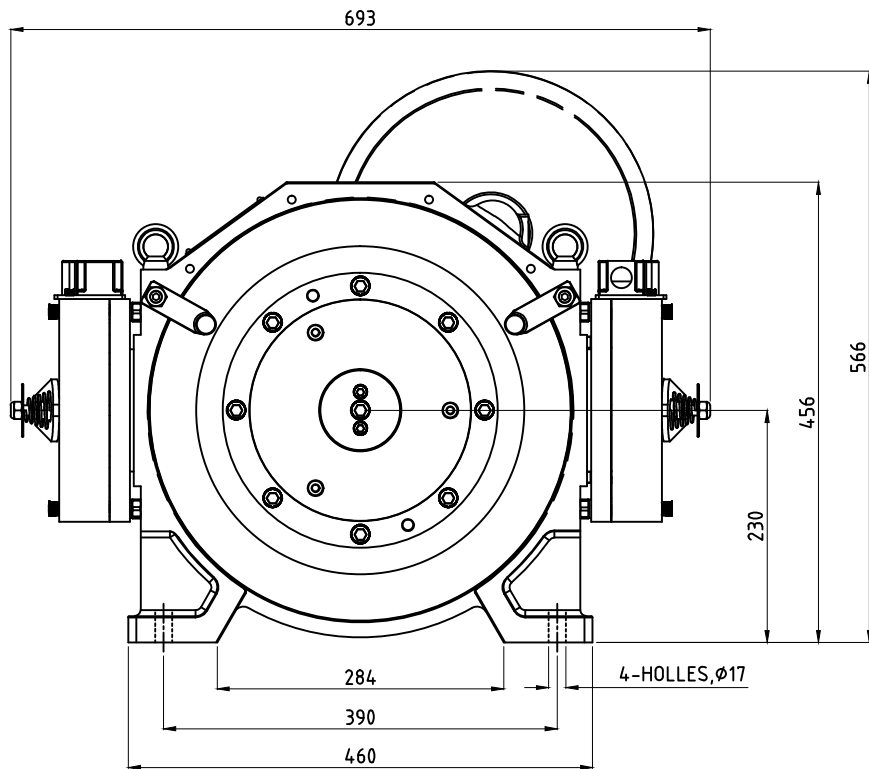

# ALL DIMENTIONS ARE IN MM.

MATERIAL :		DIMENSIONS WITH TOLERANCE AND ★ (MARK) ARE CRITICAL.		WEIGHT : 205 KG
RAW PART NO. :		MODEL : TG-0806 - 325 (8MM X 4 ROPE)		
		NAME	DATE	TITLE :
		DRN. NISHANT	28/10/18	
		CHKD.		
		APPD.		FINISH PART NO. :
		SCALE : NTS		
		~	FILING	SHEET 1 of 1
		▽	MACHINING	
		▽▽	FINE MACHINING	
		▽▽▽	GRINDING	
SR.	REVISION DESCRIPTION	DATE	NAME	

THIS DRAWING IS THE PROPERTY OF **TECTRONICS, RAJKOT**  
IT SHOULD NOT BE COPIED OR ANY OF IT'S DETAILS DIVULGED  
TO A THIRD PARTY WITHOUT OUR PRIOR PERMISSION IN WRITING  
& MUST BE RETURNED TO US ON REQUEST.

**TECTRONICS ENGINEERS**  
**RAJKOT**

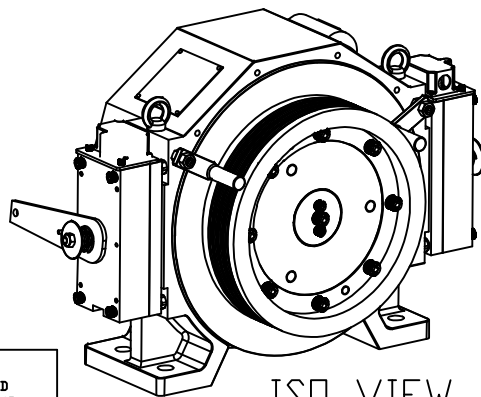
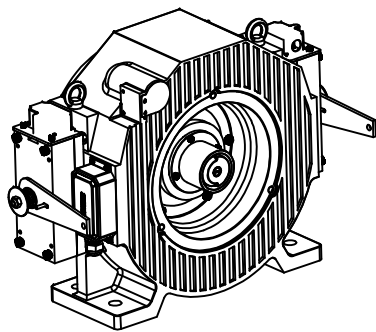
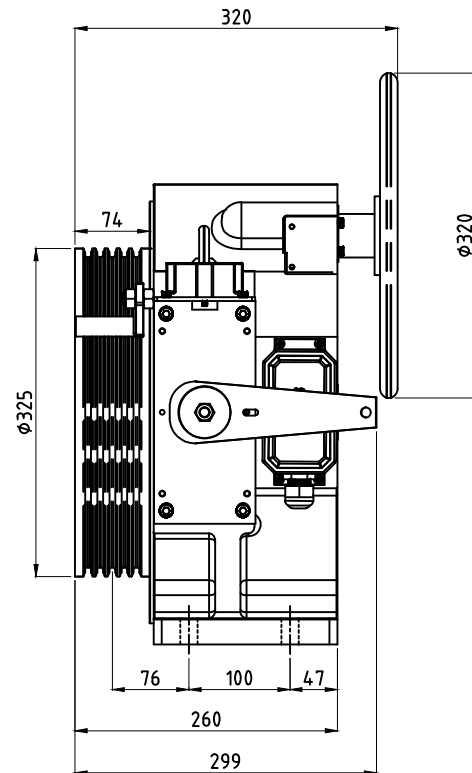
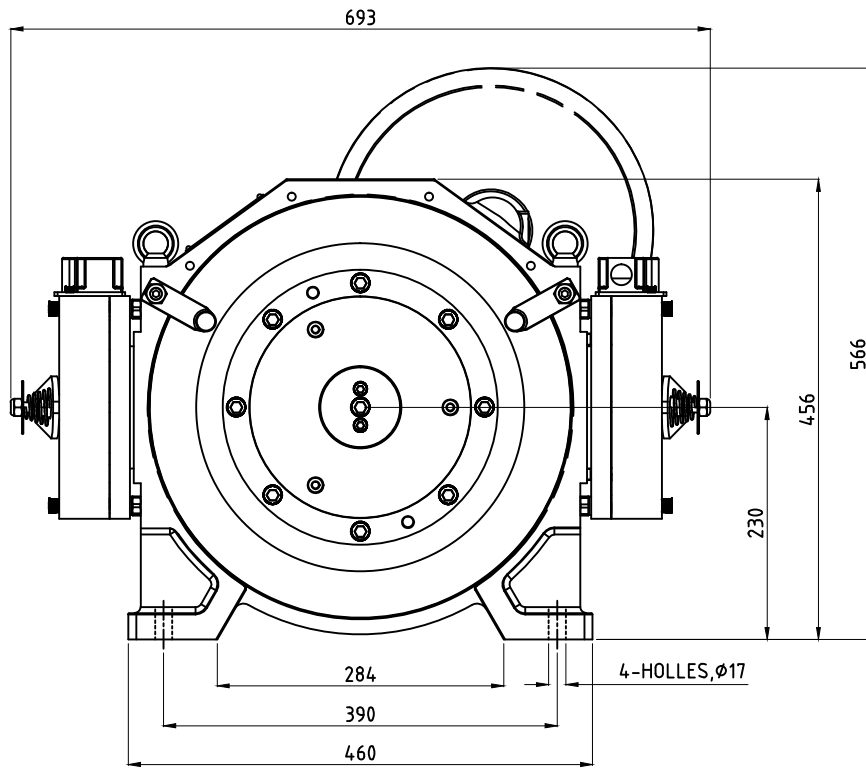

# ALL DIMENTIONS ARE IN MM.

MATERIAL :		DIMENSIONS WITH TOLERANCE AND ★ (MARK) ARE CRITICAL.		WEIGHT : 205 KG
RAW PART NO. :		MODEL : TG-0808 - 325 (8MM X 5 ROPE)		
		NAME	DATE	TITLE :
		DRN. NISHANT	28/10/'18	
		CHKD.		
		APPD.		FINISH PART NO. :
		SCALE : NTS		
		~	FILING	<b>TECTRONICS ENGINEERS</b> <b>RAJKOT</b>
		▽	MACHINING	
		▽▽	FINE MACHINING	
		▽▽▽	GRINDING	
SR.	REVISION DESCRIPTION	DATE	NAME	

THIS DRAWING IS THE PROPERTY OF **TECTRONICS, RAJKOT**  
 IT SHOULD NOT BE COPIED OR ANY OF IT'S DETAILS DIVULGED  
 TO A THIRD PARTY WITHOUT OUR PRIOR PERMISSION IN WRITING  
 & MUST BE RETURNED TO US ON REQUEST.

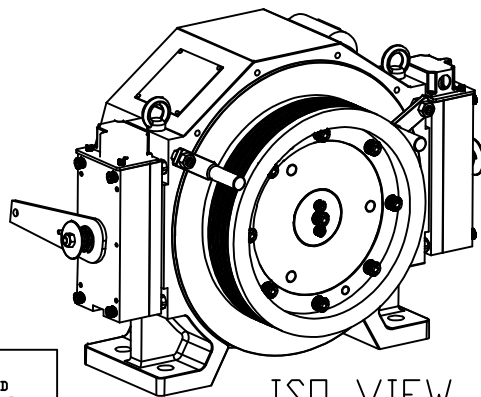
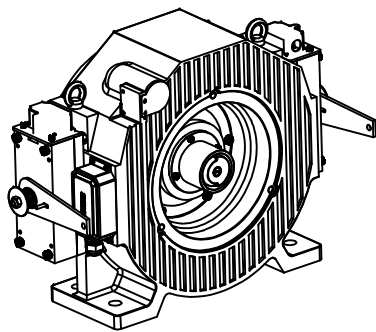
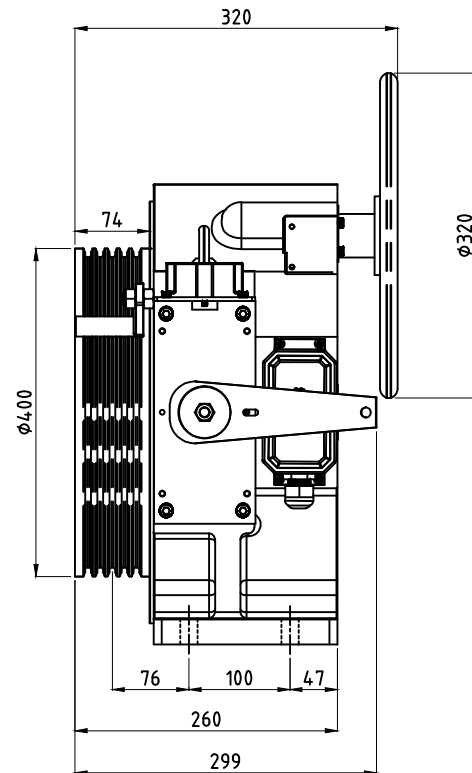
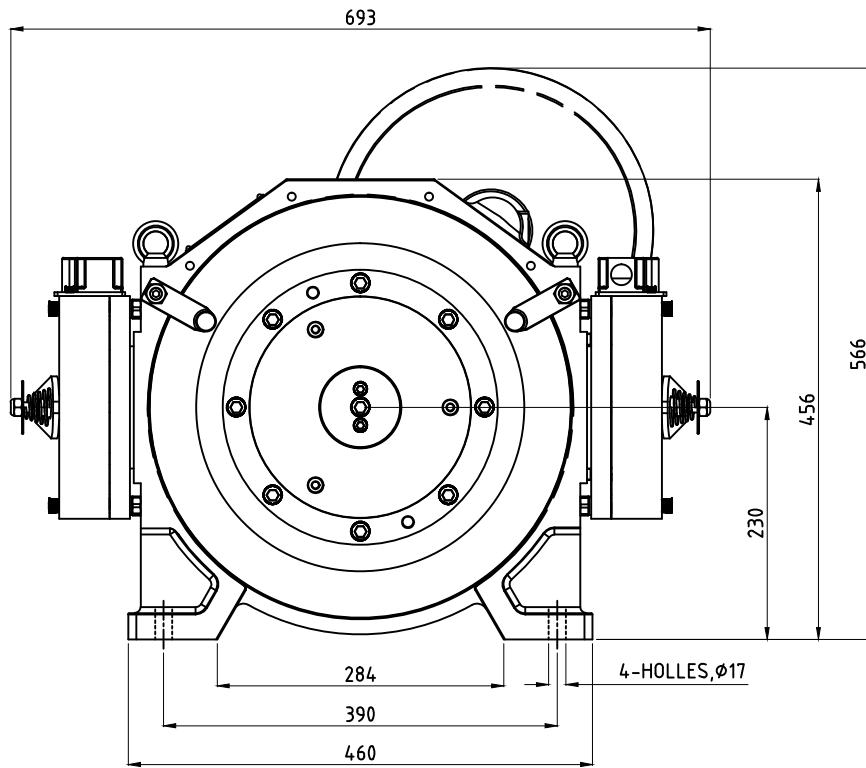

# ALL DIMENTIONS ARE IN MM.

MATERIAL :		DIMENSIONS WITH TOLERANCE AND ★ (MARK) ARE CRITICAL.		WEIGHT : 205 KG
RAW PART NO. :		MODEL : TG-0808 - 400 (8MM X 5 ROPE)		
		NAME	DATE	TITLE :
		DRN. NISHANT	28/10/'18	
		CHKD.		
		APPD.		FINISH PART NO. :
		SCALE : NTS		
		~	FILING	SHEET 1 of 1
		▽	MACHINING	
		▽▽	FINE MACHINING	
		▽▽▽	GRINDING	
SR.	REVISION DESCRIPTION	DATE	NAME	

THIS DRAWING IS THE PROPERTY OF **TECTRONICS, RAJKOT**  
IT SHOULD NOT BE COPIED OR ANY OF IT'S DETAILS DIVULGED  
TO A THIRD PARTY WITHOUT OUR PRIOR PERMISSION IN WRITING  
& MUST BE RETURNED TO US ON REQUEST.

**TECTRONICS ENGINEERS**  
**RAJKOT**

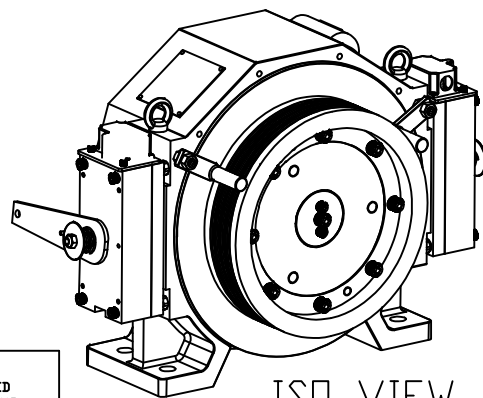
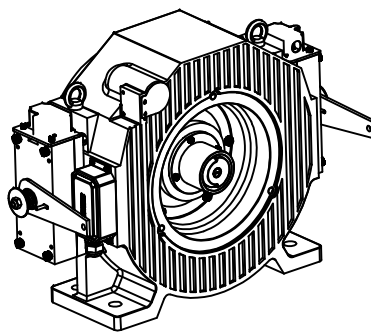
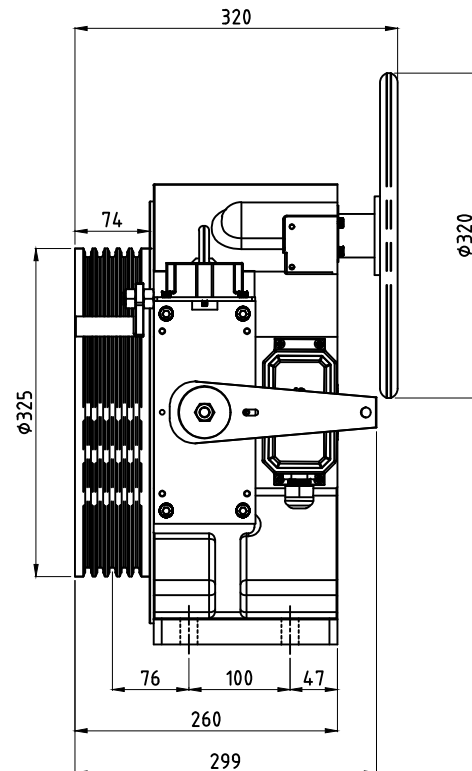
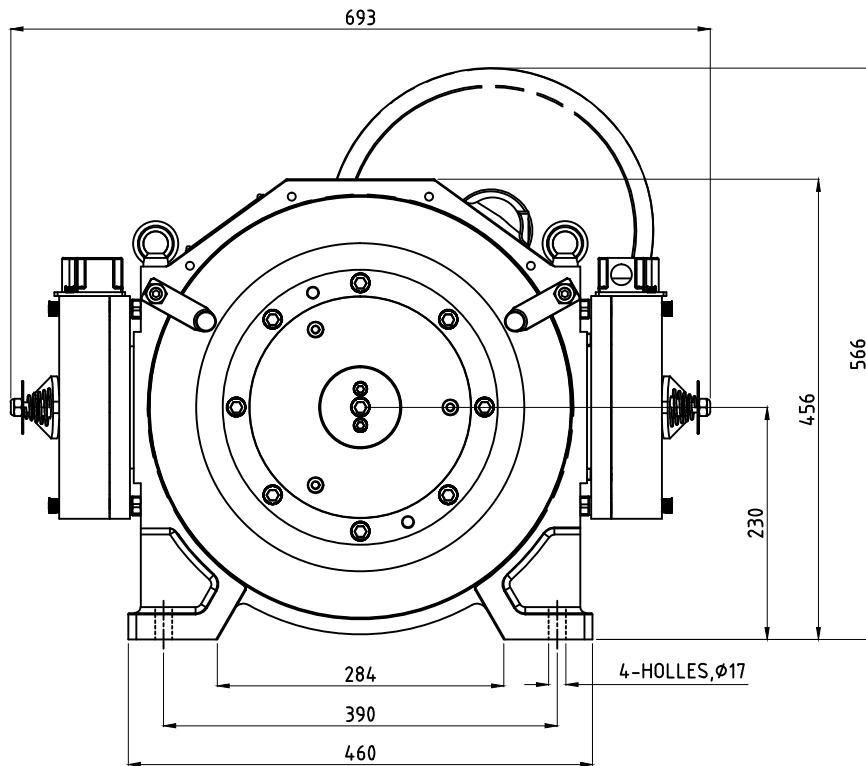

# ALL DIMENTIONS ARE IN MM.

MATERIAL :		DIMENSIONS WITH TOLERANCE AND ★ (MARK) ARE CRITICAL.		WEIGHT : 205 KG
RAW PART NO. :		MODEL : TG-0810 - 325 (8MM X 5 ROPE)		
		NAME	DATE	TITLE :
		DRN. NISHANT	28/10/'18	
		CHKD.		
		APPD.		FINISH PART NO. :
		SCALE : NTS		
		~	FILING	<b>TECTRONICS ENGINEERS</b> <b>RAJKOT</b>
		▽	MACHINING	
		▽▽	FINE MACHINING	
		▽▽▽	GRINDING	
SR.	REVISION DESCRIPTION	DATE	NAME	

THIS DRAWING IS THE PROPERTY OF **TECTRONICS, RAJKOT**  
 IT SHOULD NOT BE COPIED OR ANY OF IT'S DETAILS DIVULGED  
 TO A THIRD PARTY WITHOUT OUR PRIOR PERMISSION IN WRITING  
 & MUST BE RETURNED TO US ON REQUEST.